

YAMAHA

PARTS CATALOGUE

YZ465H (4V4)

114V4-300E1



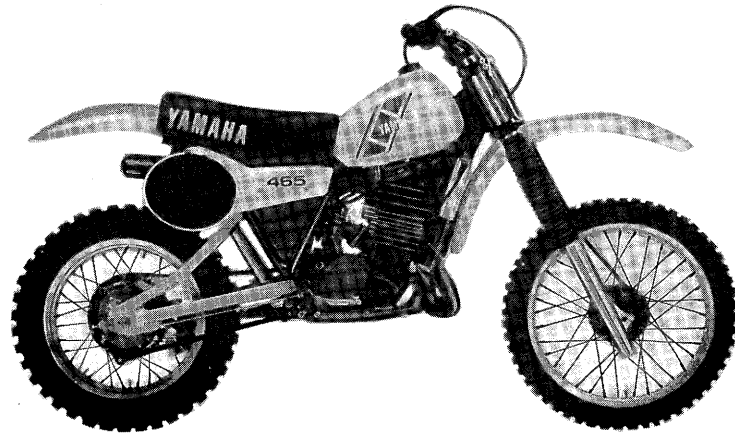

FOREWORD

This Parts Catalogue is related to the parts in use for the Yamaha YZ 465H (4V4).
When you are ordering replacement parts for the YZ 465H (4V4), refer to this Parts Catalogue and quote both part numbers and part names correctly.

1. Modifications or additions which have been made after issue of the Parts Catalogue will be announced in the Yamaha Parts News.
It is advisable that according to the Yamaha Parts News you make necessary corrections to the Parts Catalogue on hand to keep it up-to-date.

2. Abbreviations

The following abbreviations are used in this Parts Catalogue.

- U.R. Use size (thickness) and/or number as required.
- U.N. Use as many as you need.
- A.P. Alternate Parts
- L.M. Local Made
- F# Frame No. (Applicable machine No.)

3. The parts marked with (*) in the parts number column of this Catalogue are not supplied with by Yamaha, those have to be found locally.
4. Parts, which are to be supplied in the form of assemblies, are listed with an indention of one letter's space, and a dot (.) is put against the name of each part.

EXAMPLE CARBURETOR ASS'Y
 . JET; pilot
 . NOZZLE, main

5. Indication of No. of constituent parts for assembly

The numeral appearing to the right of each constituent part under the description indicates the quantity of such parts for each individual assembly unit.

EXAMPLE

Part No.	Description	Q'ty	Remarks
2F5-83310-60	FRONT FLASHER LIGHT ASS'Y	2	
115-83311-60	. BULB (6V-18W)	1	
1M1-83309-60	. REFLECTOR	1	

6. Initial Serial No. and Color Code

(A) Frame Serial No.	4V4-000101 and following
(B) Engine Serial No.	4V4-000101 and following

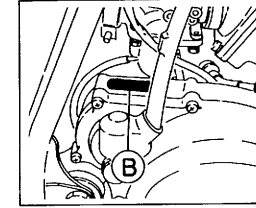
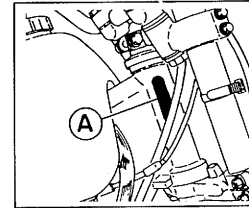

Color Code	Color Name	Abbreviate
	Clean White	

7. Applicable colors of graphics are represented in the "Remarks" column by the letter(s) appropriately picked out of the full word(s) showing such colors.

EXAMPLE

Part No.	Description	Q'ty	Remarks
2N4-24110-00-X5	FUEL TANK COMP.	1	MAXIM RED
3J1-24240-10	. GRAPHIC, fuel tank set	1	for MXR

CONTENTS

ENGINE

Fig. 1	Cylinder	1
Fig. 2	Crankshaft · Piston	2
Fig. 3	C.D.I Magneto	3
Fig. 4	Intake	4
Fig. 5	Carburetor	5
Fig. 6	Exhaust	7
Fig. 7	Crankcase	8
Fig. 8	Crankcase Cover	9
Fig. 9	Kick Starter	10
Fig. 10	Clutch	11
Fig. 11	Transmission	13
Fig. 12	Shift Cam · Fork	15
Fig. 13	Shift Shaft · Pedal	16

CHASSIS

Fig. 14	Frame · Tool	17
Fig. 15	Front Fender · Rear Fender	18
Fig. 16	Side Cover	19
Fig. 17	Rear Arm	20
Fig. 18	Rear Suspension	22
Fig. 19	Steering	24
Fig. 20	Front Fork	25
Fig. 21	Fuel Tank	27
Fig. 22	Seat	28
Fig. 23	Front Wheel	29
Fig. 24	Rear Wheel	31
Fig. 25	Handlebar · Cable	33
Fig. 26	Stand · Footrest	35
Fig. 27	Electrical 1	36
Fig. 28	Handle Switch · Lever	37

ALTERNATE PARTS

Fig. 29	Alternate (Chassis)	38
---------	---------------------	----

REPAIR KIT

Fig. 30	Repair Kit	39
---------	------------	----

INDEX

Numerical Index
Parts Name Index

FIG. 1 CYLINDER

REF. NO.	PART NO.	DESCRIPTION	Q'TY	REMARKS
1	3R5-11111-00	HEAD, cylinder 1	1	
2	3R5-11181-00	GASKET, cylinder head 1	1	
3	*	PLUG, sPark (CHAMPION N-3)	1	LM
4	90116-08321	BOLT, stud	6	
5	90179-08299	NUT	6	
6	4V4-11311-00	CYLINDER 1	1	
7	3R5-11351-00	GASKET, cylinder	1	
8	90116-12315	BOLT, stud	2	
9	90116-12316	BOLT, stud	2	
10	95701-12100	NUT, flange	4	
11	91810-17016	PIN, dowel	2	

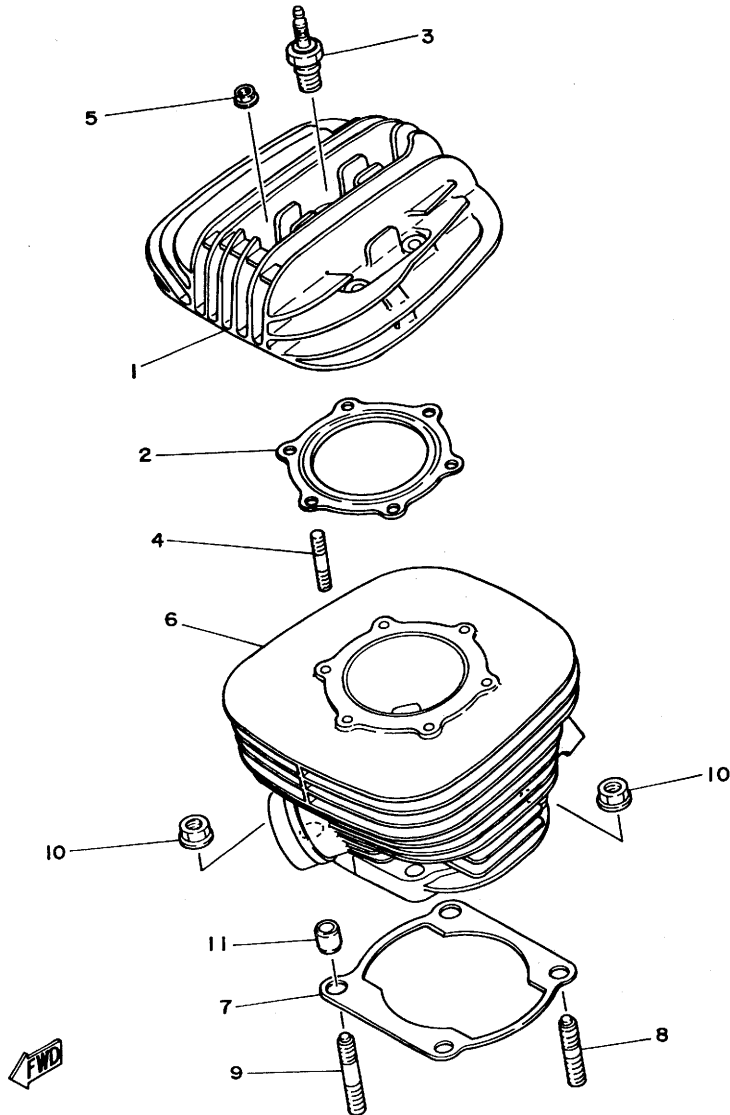

B2

FIG. 2 CRANKSHAFT.PISTON

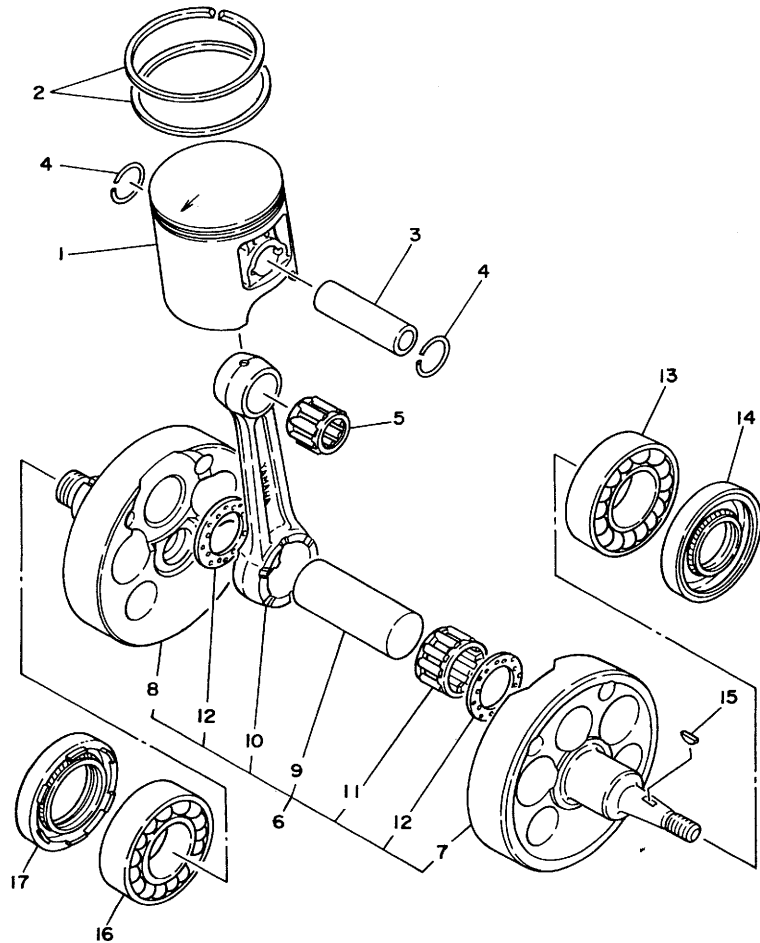

REF. NO.	PART NO.	DESCRIPTION	Q'TY	REMARKS
1	3R5-11631-00-94	PISTON (STD)	1	UR
	3R5-11631-00-96	PISTON (STD)	1	UR
	3R5-11635-00	PISTON (1ST O/S 0.25MM)	1	AP
	3R5-11636-00	PISTON (2ND O/S 0.50MM)	1	AP
	3R5-11637-00	PISTON (3RD O/S 0.75MM)	1	AP
	3R5-11638-00	PISTON (4TH O/S 1.00MM)	1	AP
2	3R5-11601-00	PISTON RING SET (STD)	1	
	3R5-11601-10	PISTON RING SET (1ST D/S)	1	AP
	3R5-11601-20	PISTON RING SET (2ND D/S)	1	AP
	3R5-11601-30	PISTON RING SET (3RD D/S)	1	AP
	3R5-11601-40	PISTON RING SET (4TH D/S)	1	AP
3	275-11633-00	PIN, Piston	1	
4	93450-19052	CIRCLIP	2	
5	93310-418E9	BEARING, cylindrical	1	
6	3R5-11400-00	CRANKSHAFT ASSY	1	
7	3R5-11412-00	•CRANK 1	1	
8	3R5-11422-00	•CRANK 2	1	
9	3R5-11681-00	•PIN, crank 1	1	
10	3R5-11651-00	•ROD, connecting	1	
11	93310-42541	•BEARING, cylindrical	1	
12	90209-25085	•WASHER	2	
13	93306-30615	BEARING (B6306)	1	
14	93103-30092	OIL SEAL	1	
15	90280-03017	KEY, woodruff	1	
16	93306-30615	BEARING (B6306)	1	
17	93103-40091	OIL SEAL	1	

FIG. 3 C.D.I MAGNETO

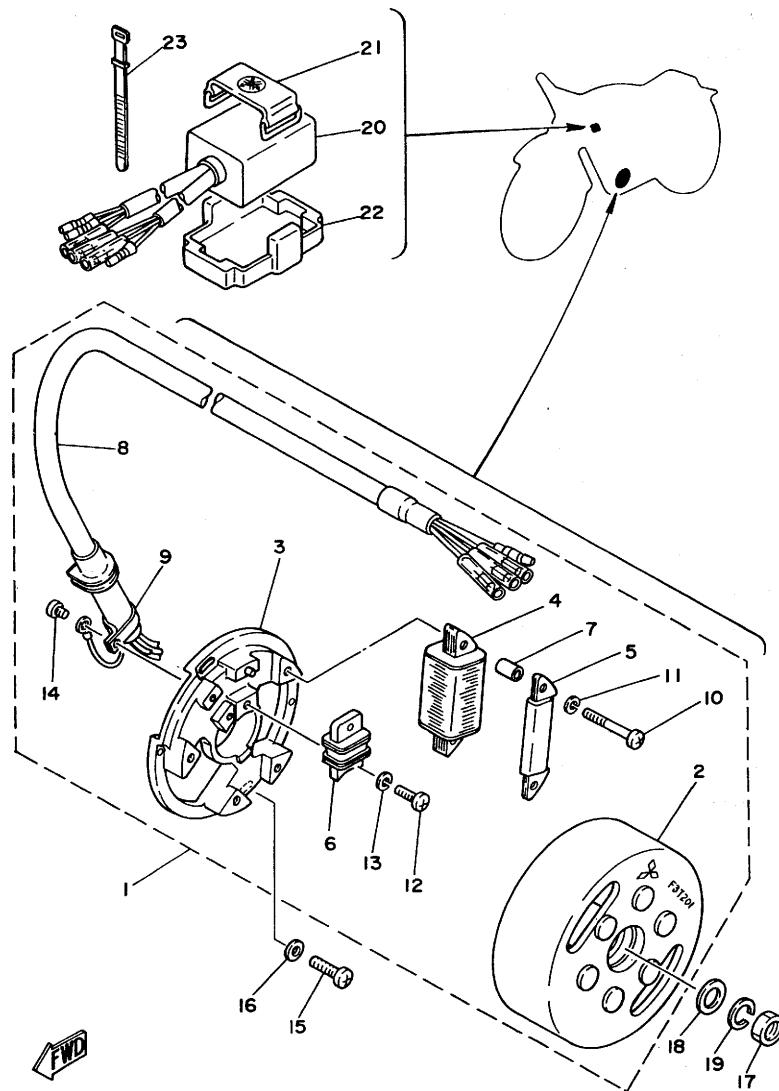

REF. NO.	PART NO.	DESCRIPTION	Q'TY	REMARKS
1	3R5-85500-20	C.D.I. MAGNETO ASSY	1	
2	3R5-85550-20	.ROTOR ASSY	1	
3	3R5-85509-20	.BASE, magneto	1	
4	3R5-85511-20	.COIL, source	1	
5	3R5-85512-20	.COIL, source	1	
6	2W6-85580-20	.COIL, Pulser	1	
7	1W2-85516-20	.SPACER	2	
8	3R5-85515-20	.LEAD WIRE ASSY	1	
9	104-81328-20	.CLAMP	1	
10	98501-04035	.SCREW, Pan head	2	
11	92901-04100	.WASHER, sPring	2	
12	98501-04014	.SCREW, Pan head	1	
13	92901-04100	.WASHER, sPring	1	
14	110-81345-21	.SCREW, Pan head	1	
15	92501-06020	SCREW, Pan head	3	
16	92901-06600	WASHER, Plate	3	
17	90170-12067	NUT	1	
18	90201-12593	WASHER, Plate	1	
19	92901-12100	WASHER, sPring	1	
20	3R5-85540-20	C.D.I. UNIT ASSY	1	
21	116-82131-00	BAND, battery	1	
22	3R5-85547-00	DAMPER	1	
23	256-83936-00	BAND, switch cord	1	

B4

FIG. 4 INTAKE

REF. NO.	PART NO.	DESCRIPTION	Q'TY	REMARKS
1	3R5-13610-00	REED VALVE ASSY	1	
2	3R5-13613-00	•REED, valve	1	
3	2X5-13616-00	•STOPPER, reed valve	2	
4	98501-03008	•SCREW, Pan head	6	
5	92901-03100	•WASHER, sPrin8	6	
6	2K7-13621-00	GASKET, valve seat	1	
7	3R4-13565-00	JOINT, carburetor	1	
8	90460-51109	CLAMP, hose	1	
9	91316-06020	BOLT	4	
10	90460-68120	CLAMP, hose	1	
11	4V4-W1441-00	AIR CLEANER CASE COMP.	1	
12	1W4-14457-00	•SEAL	1	
13	90467-20030	•CLIP	1	
14	3R4-W1442-01	ELEMENT, air cleaner	1	
15	3R4-14458-00	GUIDE	1	
16	4V4-14459-00	HOLDER, guide	1	
17	90175-06012	NUT, wing	2	
18	90480-13197	GROMMET	1	
19	97301-06016	BOLT	4	
20	92901-06100	WASHER, sPrin8	4	
21	4V4-14484-00	PLATE, cleaner case fitting	1	
22	4V4-14499-00	STAY 2	1	

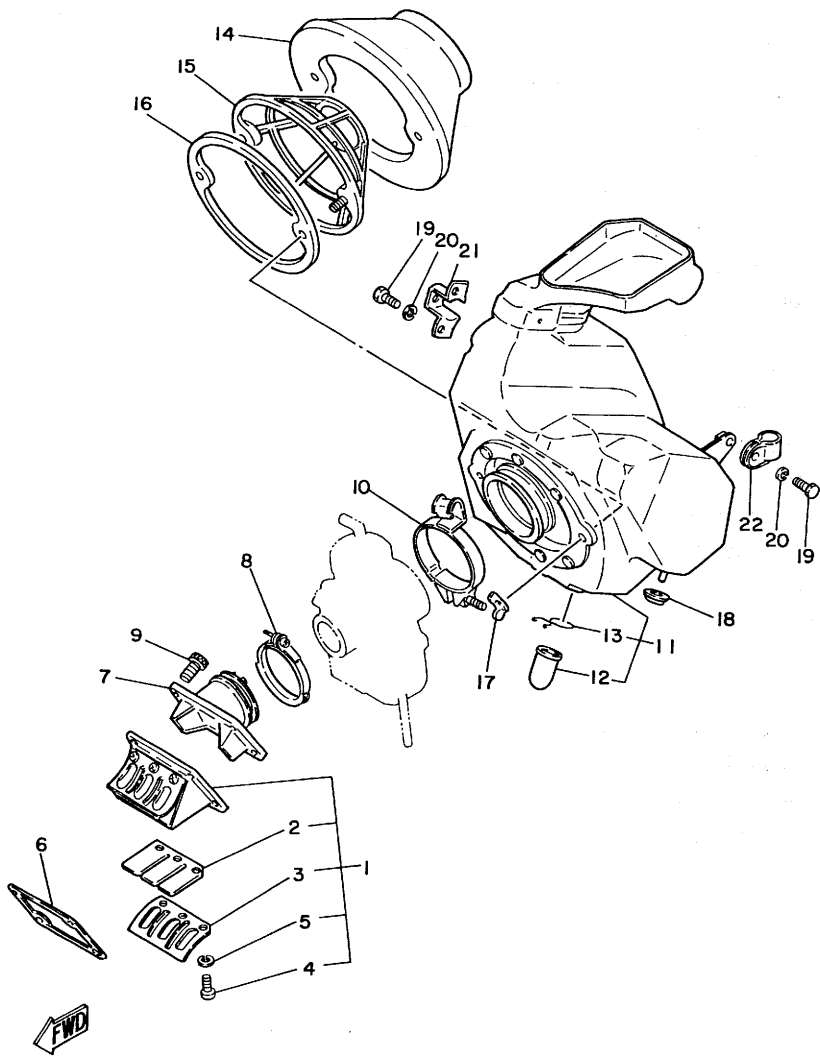
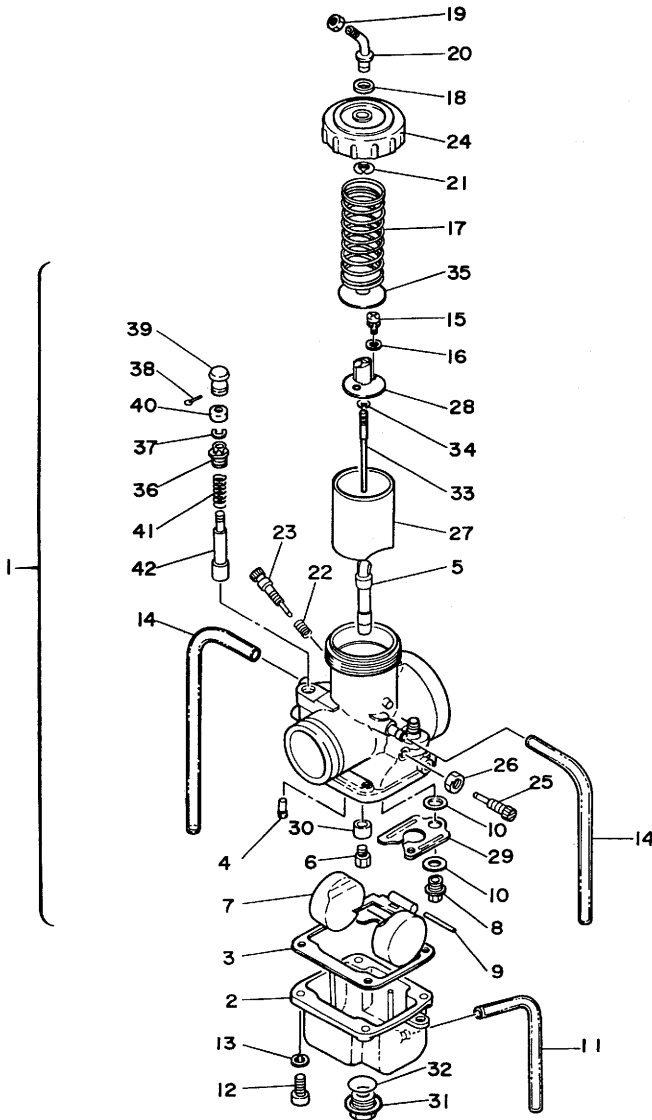
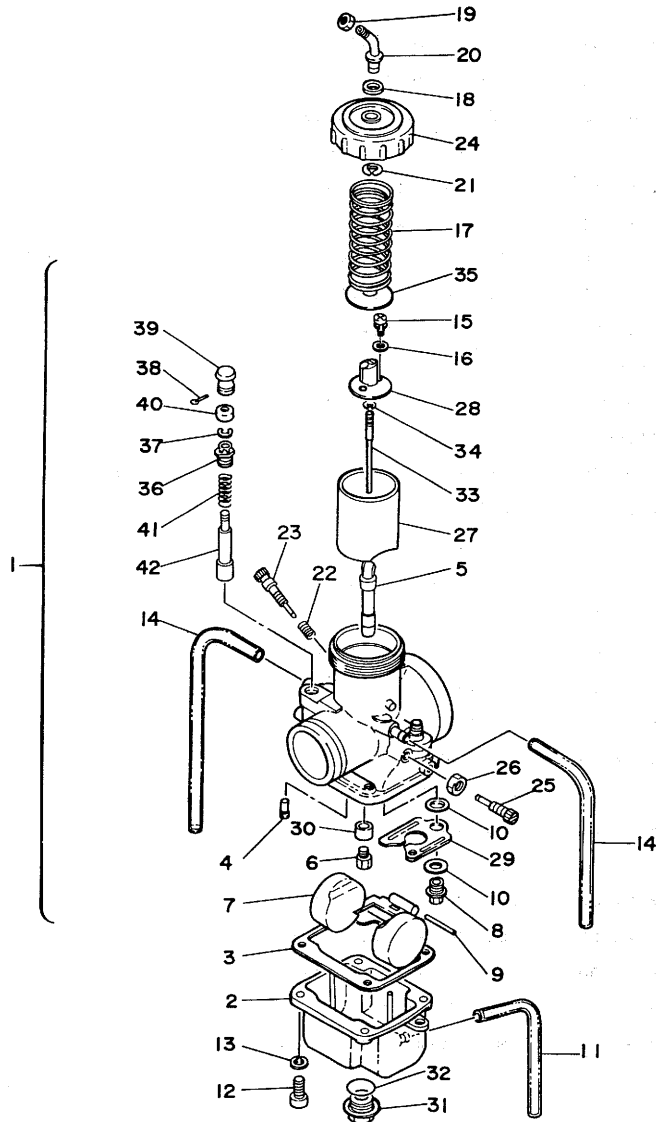

FIG. 5 CARBURETOR



REF. NO.	PART NO.	DESCRIPTION	Q'TY	REMARKS
1	4V4-14101-00	CARBURETOR ASSY 1	1	
2	3R4-14181-16	.BODY, float chamber 1	1	
3	363-14184-00	.GASKET, float chamber	1	
4	193-14142-45	.JET, Pilot (#45.0)	1	
5	510-14141-52	.NOZZLE, main	1	
6	137-14143-78	.JET, main (#390)	1	UR STD
	137-14143-76	.JET, main (#380)	1	UR
	137-14143-80	.JET, main (#400)	1	UR
7	2N7-14185-00	.FLOAT	1	
8	363-14190-35	.NEEDLE VALVE ASSY	1	
9	537-14186-00	.PIN, float	1	
10	239-14195-00	.WASHER, needle valve	2	
11	2K7-14197-00	.PIPE	1	
12	98501-05015	.SCREW, Pan head	4	
13	92902-05100	.WASHER, sPring	4	
14	310-14197-00	.PIPE	2	
15	97602-03108	.SCREW, Pan head with washer	2	
16	92902-03600	.WASHER	2	
17	363-14131-00	.SPRING, throttle valve	1	
18	8F2-14147-00	.O-RING	1	
19	127-14161-00	.NUT, cable adjustin&	1	
20	3R4-14155-00	.GUIDE, cable	1	
21	363-14137-00	.CLIP	1	
22	127-14134-00	.SPRING, air adjustin&	1	
23	152-14123-00	.SCREW, air adjustin&	1	
24	3R4-14158-00	.TOP, mixin& chamber	1	
25	2A0-14122-00	.SCREW, throttle	1	
26	802-14161-00	.NUT, cable adjustin&	1	

FIG. 5 CARBURETOR



REF. NO.	PART NO.	DESCRIPTION	Q'TY	REMARKS
27	510-14112-30	•VALVE, throttle 1	1	
28	509-14274-00	•CONNECTOR	1	
29	3R4-14146-00	•PLATE	1	
30	2X8-14153-00	•WASHER, main Jet	1	
31	510-14115-00	•PLUG, screw	1	
32	558-14147-00	•O-RING	1	
33	239-14116-16	•NEEDLE	1	
34	164-14137-00	•CLIP	1	
35	509-14136-00	•SEAT, sPring	1	
36	152-14174-00	•CAP, PlunGer	1	
37	353-14138-00	•CLIP, PlunGer	1	
38	91402-16015	•PIN, cotter	1	
39	737-14261-00	•HOLDER	1	
40	637-14173-00	•COVER, PlunGer caP	1	
41	156-14135-00	•SPRING, PlunGer	1	
42	737-14171-00	•PLUNGER, starter	1	

B7

FIG. 6 EXHAUST

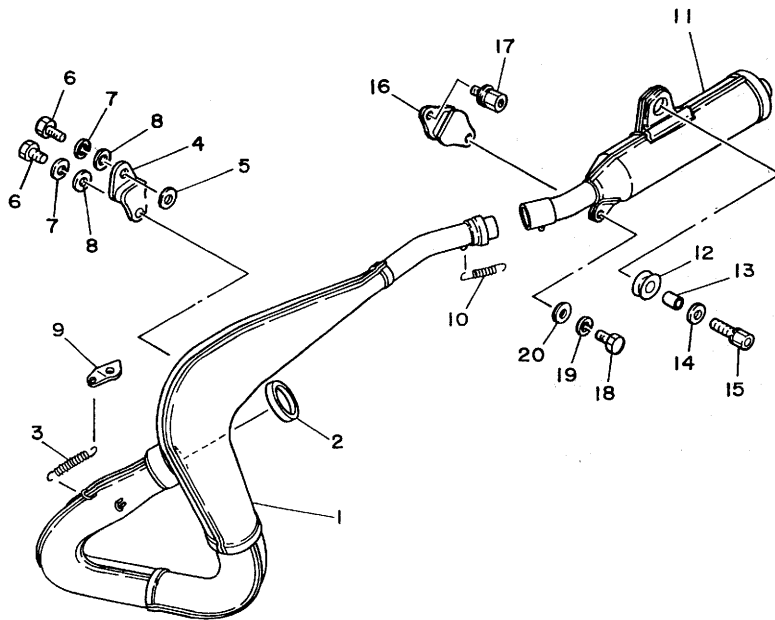

REF. NO.	PART NO.	DESCRIPTION	Q'TY	REMARKS
1	4V4-14610-00	EXHAUST PIPE ASSY 1	1	
2	3R4-14613-00	GASKET, exhaust Pipe	1	
3	90507-20030	SPRING, tension	3	
4	3R4-14781-02	STAY, muffler 2	1	
5	92901-08200	WASHER, Plain	1	
6	97301-08016	BOLT	2	
7	92901-08100	WASHER, sPring	2	
8	92901-08600	WASHER, Plate	2	
9	3R5-14619-00	HOOK, sPring	1	
10	90506-20223	SPRING, tension	1	
11	4V4-14753-00	SILENCER, exhaust	1	
12	565-14747-00	DAMPER, muffler	1	
13	90387-08258	COLLAR	1	
14	156-24186-00	WASHER, sPecial	1	
15	90109-08512	BOLT	1	
16	565-14771-00	STAY, muffler 1	1	
17	90109-06551	BOLT	1	
18	97301-06016	BOLT	1	
19	92901-06100	WASHER, sPring	1	
20	92901-06600	WASHER, Plate	1	

FWD

B8

FIG. 7 CRANKCASE

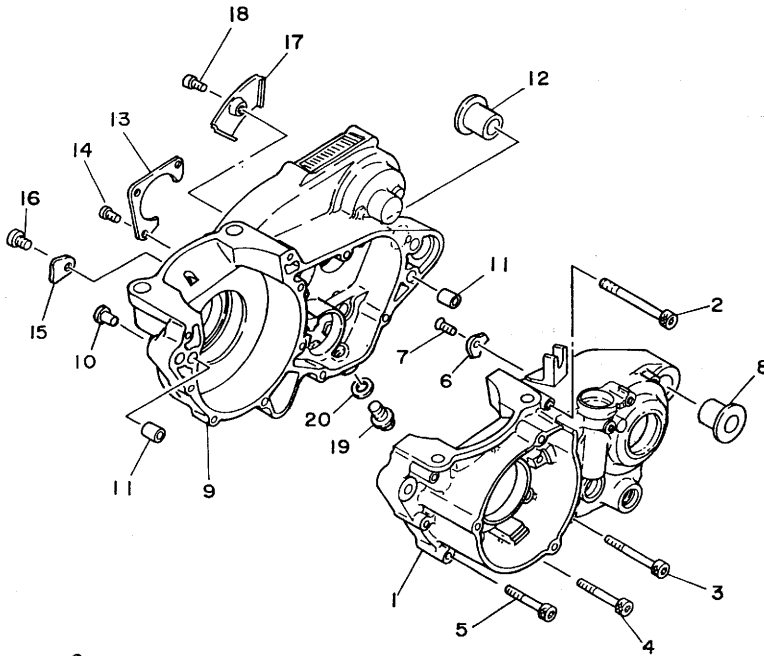
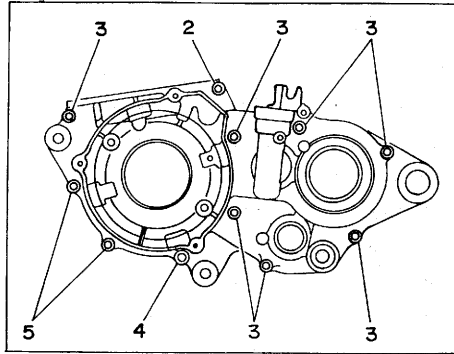

REF. NO.	PART NO.	DESCRIPTION	Q'TY	REMARKS
1	3R5-15111-00	CRANKCASE 1	1	
2	91316-06075	BOLT	1	
3	91316-06060	BOLT	7	
4	91316-06050	BOLT	1	
5	91316-06045	BOLT	2	
6	3R4-15383-00	PLATE, bearing cover	1	
7	92701-06012	SCREW, flat head	1	
8	90387-16776	COLLAR	1	
9	3R5-15121-02	CRANKCASE 2	1	
10	90338-07011	PLUG	1	
11	91810-05016	PIN, dowel	4	
12	90387-16776	COLLAR	1	
13	3R4-15381-00	PLATE, bearing cover	1	
14	92501-06012	SCREW, Pan head	3	
15	4V4-15118-00	HOLDER	1	
16	92501-06010	SCREW, Pan head	1	
17	3R4-15113-00	PLATE	1	
18	92501-06012	SCREW, Pan head	1	
19	90340-12059	PLUG, straight screw	1	
20	90430-12038	GASKET	1	

FIG. 8 CRANKCASE COVER

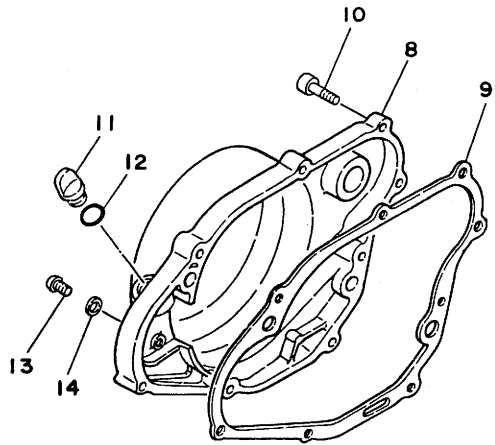

REF. NO.	PART NO.	DESCRIPTION	Q'TY	REMARKS
1	3R5-15411-00	COVER, crankcase 1	1	
2	4V4-15451-00	GASKET, crankcase cover	1	
3	92506-06035	SCREW, Pan head	3	
4	3R4-15421-00	COVER, crankcase 2	1	
5	92506-06025	SCREW, Pan head	1	
6	92906-06100	WASHER, sPring	1	
7	92906-06600	WASHER, Plate	1	
8	3R4-15431-01	COVER, crankcase 3	1	
9	3R4-15462-00	GASKET, crankcase cover 3	1	
10	91316-06025	BOLT	8	
11	1G8-15362-00	PLUG, oil level	1	
12	93210-14104	O-RING	1	
13	92506-06008	SCREW, Pan head	1	
14	90430-06016	GASKET	1	

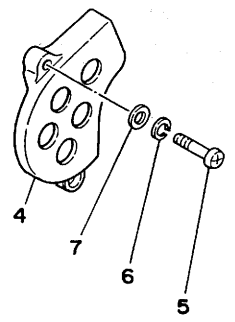
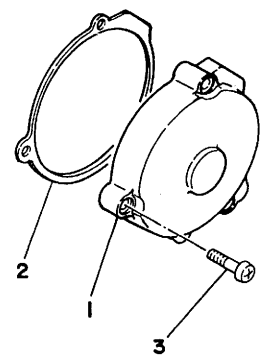
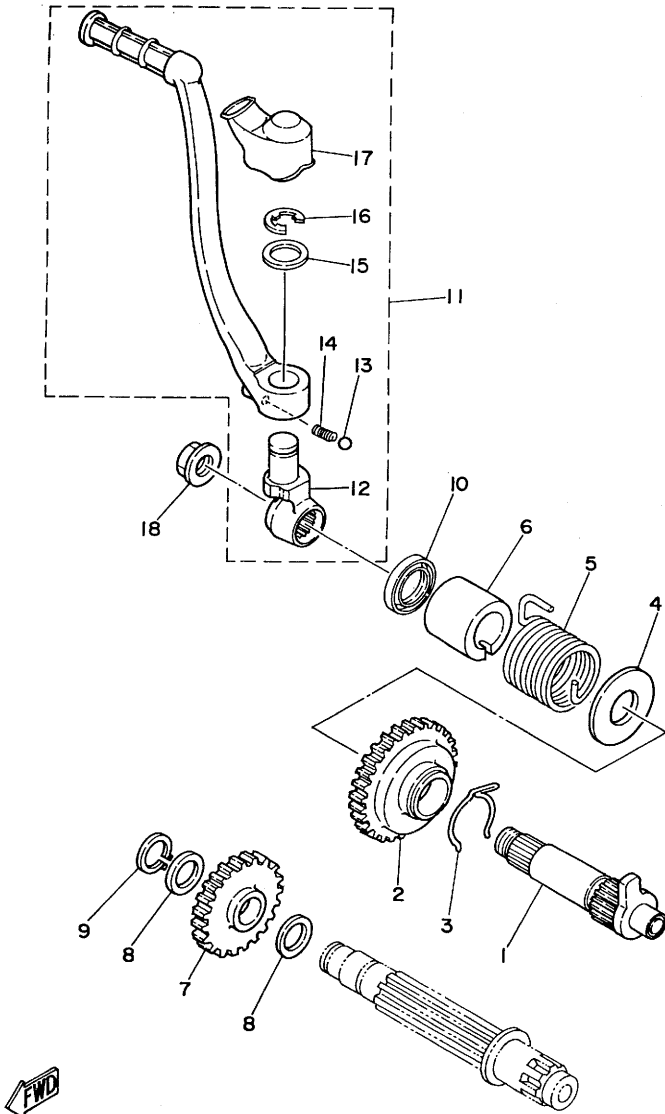

FIG. 9 KICK STARTER

REF. NO.	PART NO.	DESCRIPTION	Q'TY	REMARKS
1	3R4-15660-00	KICK AXLE ASSY	1	
2	3R4-15641-00	GEAR, kick (26T)	1	
3	90468-26048	CLIP	1	
4	90201-20358	WASHER, Plate	1	
5	90508-30422	SPRING, torsion	1	
6	3R4-15664-00	GUIDE, sPring	1	
7	3R4-15651-00	GEAR, sProcket idle (21T)	1	
8	90201-17545	WASHER, Plate	2	
9	93410-17008	CIRCLIP	1	
10	93109-20014	OIL SEAL	1	
11	4V3-15620-00	KICK CRANK ASSY	1	
12	4V3-15621-00	•BOSS, kick crank	1	
13	93507-32009	•BALL	1	
14	90501-12081	•SPRING, comPression	1	
15	90201-15234	•WASHER, Plate	1	
16	93430-10016	•CIRCLIP	1	
17	2K7-15618-00	•COVER, kick lever	1	
18	90179-12244	NUT	1	



B11

FIG. 10 CLUTCH

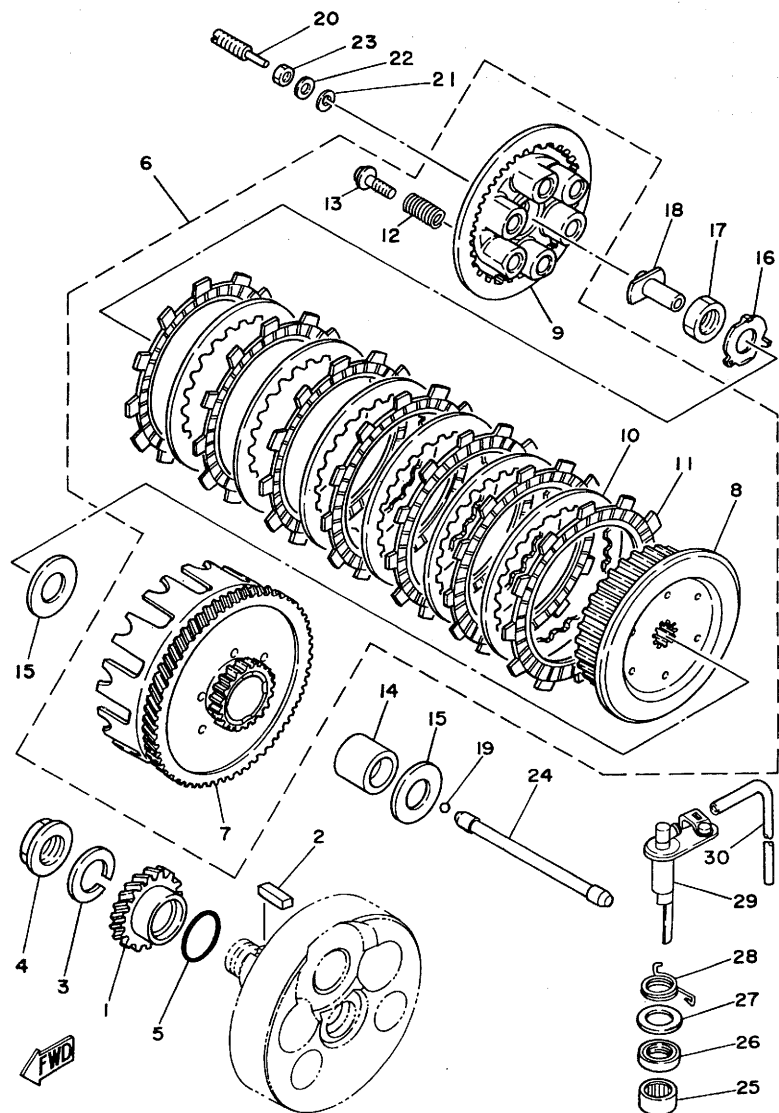

REF. NO.	PART NO.	DESCRIPTION	Q'TY	REMARKS
1	3R5-16111-00	GEAR, Primary drive (24T)	1	
2	90282-07019	KEY, straight	1	
3	92901-18100	WASHER, sPring	1	
4	90170-18089	NUT	1	
5	93210-29282	O-RING	1	
6	3R5-16300-00	CLUTCH ASSY	1	
7	3R4-16150-00	•PRIMARY DRIVEN GEAR COMP.(63T)	1	
8	3R4-16371-00	•BOSS, clutch	1	
9	1M1-16351-00	•PLATE, Pressure 1	1	
10	168-16325-00	•PLATE, clutch 2	6	
11	383-16321-00	•PLATE, friction	7	
12	90501-24408	•SPRING, comPrission	6	
13	90159-06016	•SCREW, with washer	6	
14	2K7-16181-00	SPACER 1	1	
15	2K7-16154-00	PLATE, thrust 1	2	
16	90215-20125	WASHER, lock	1	
17	90170-20255	NUT	1	
18	3R4-16356-00	ROD, Push 1	1	
19	93515-32029	BALL	1	
20	90149-08143	SCREW	1	
21	92901-08100	WASHER, sPring	1	
22	90201-08092	WASHER, Plate	1	
23	95311-08700	NUT	1	
24	3R5-16357-00	ROD, Push 2	1	
25	93315-21721	BEARING, cylindrical	1	
26	93102-17004	OIL SEAL	1	
27	90201-17327	WASHER, Plate	1	
28	90508-14423	SPRING, torsion	1	

B12

FIG. 10 CLUTCH

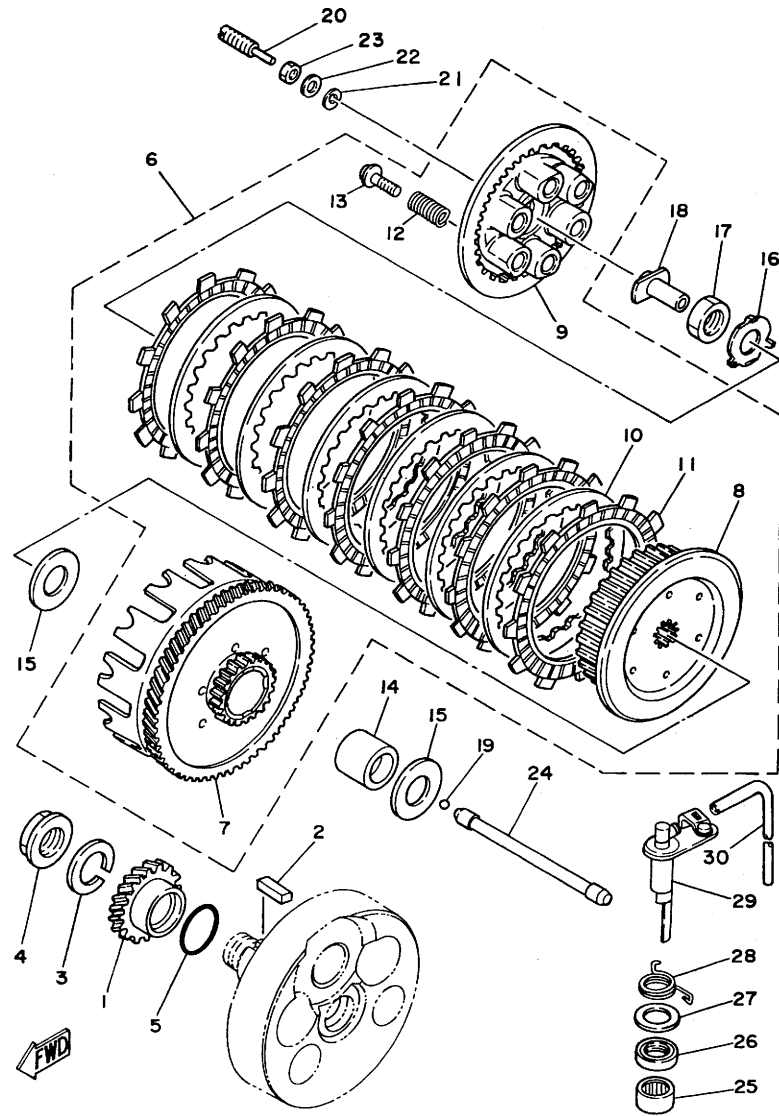

REF. NO.	PART NO.	DESCRIPTION	Q'TY	REMARKS
29	4V4-16380-00	PUSH LEVER ASSY	1	
30	90445-08577	HOSE	1	

B13

FIG. 11 TRANSMISSION

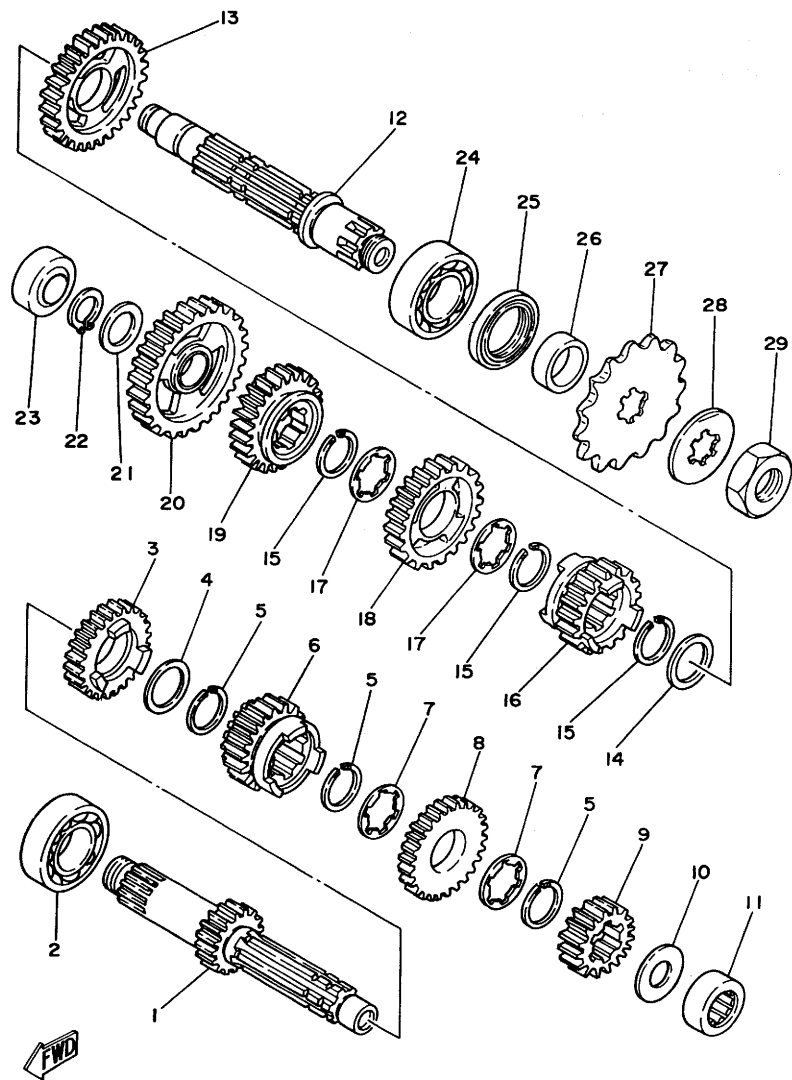

REF. NO.	PART NO.	DESCRIPTION	Q'TY	REMARKS
1	3R5-17411-00	AXLE, main (14T)	1	
2	93306-20540	BEARING	1	
3	3R5-17141-00	GEAR, 4th Pinion (22T)	1	
4	90201-25287	WASHER, Plate	1	
5	93440-25084	CIRCLIP	3	
6	3R5-17131-00	GEAR, 3rd Pinion (19T)	1	
7	90209-22082	WASHER	2	
8	3R5-17151-00	GEAR, 5th Pinion (24T)	1	
9	3R5-17121-00	GEAR, 2nd Pinion (16T)	1	
10	90201-20278	WASHER, Plate	1	
11	93311-62035	BEARING, cylindrical	1	
12	3R5-17421-00	AXLE, drive	1	
13	3R5-17221-00	GEAR, 2nd wheel (28T)	1	
14	90201-25287	WASHER, Plate	1	
15	93440-25019	CIRCLIP	3	
16	3R5-17251-00	GEAR, 5th wheel (20T)	1	
17	90209-22082	WASHER	2	
18	3R5-17231-01	GEAR, 3rd wheel (25T)	1	
19	2X5-17241-00	GEAR, 4th wheel (23T)	1	
20	3R5-17211-01	GEAR, 1st wheel (30T)	1	
21	90201-20278	WASHER, Plate	1	
22	93410-20038	CIRCLIP	1	
23	93311-62035	BEARING, cylindrical	1	
24	93306-20544	BEARING	1	
25	93102-32136	OIL SEAL	1	
26	90387-25663	COLLAR	1	
27	1W4-17461-40	SPROCKET, drive (14T)	1	UR STD
	1W4-17461-30	SPROCKET, drive (13T)	1	AP

B14

FIG. 11 TRANSMISSION

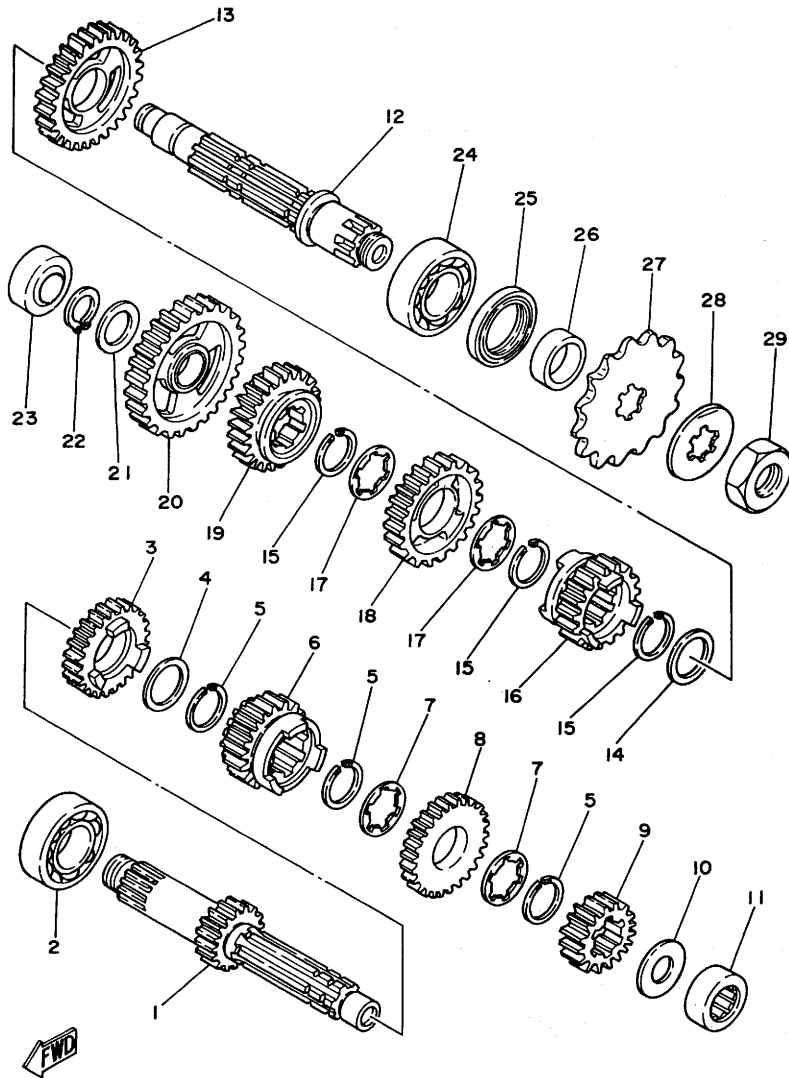

REF. NO.	PART NO.	DESCRIPTION	Q'TY	REMARKS
27	1W4-17461-50	SPROCKET, drive (15T)	1	AP
28	90215-21121	WASHER, lock	1	
29	90179-20255	NUT	1	

B15

FIG. 12 SHIFT CAM.FORK

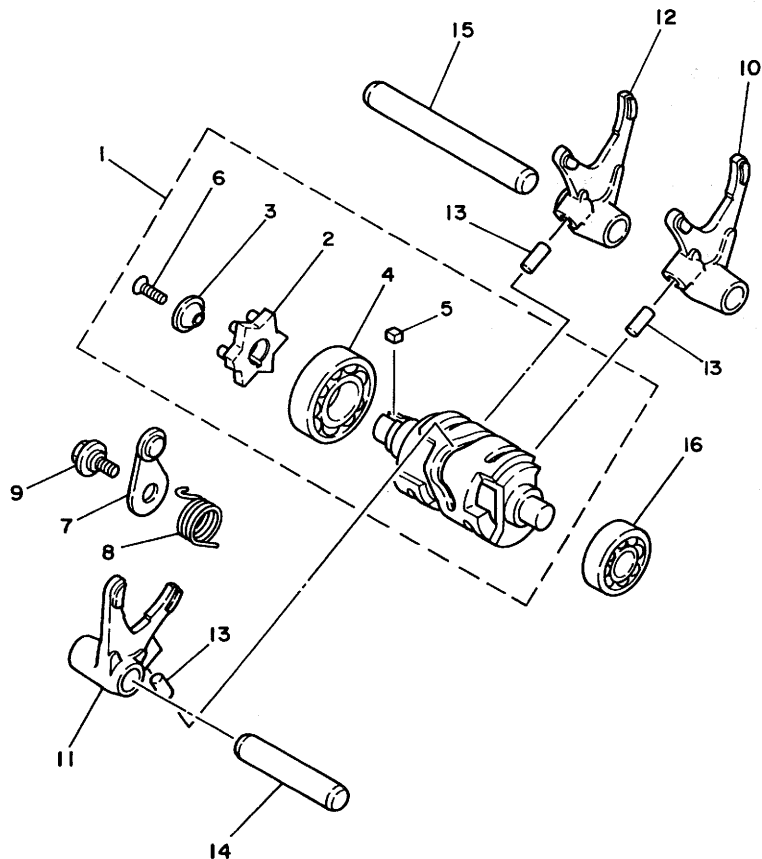

REF. NO.	PART NO.	DESCRIPTION	Q'TY	REMARKS
1	3R5-18540-01	SHIFT CAM ASSY	1	
2	3R4-18185-00	•SEGMENT	1	
3	3R4-18561-00	•PLATE, side 1	1	
4	93306-00422	•BEARING	1	
5	90282-04036	•KEY, straight	1	
6	98701-05016	•SCREW, flat head	1	
7	3R4-18140-00	STOPPER LEVER ASSY	1	
8	90508-26421	SPRING, torsion	1	
9	1W1-18177-00	BOLT, stopPer	1	
10	3R5-18511-00	FORK, shift 1	1	
11	3R5-18512-00	FORK, shift 2	1	
12	3R5-18513-00	FORK, shift 3	1	
13	93606-14154	PIN, dowel	3	
14	4V4-18531-00	BAR, shift fork guide 1	1	
15	4V4-18535-00	BAR, shift fork guide 2	1	
16	93306-20107	BEARING (B6201)	1	

FWD

C2

FIG. 13 SHIFT SHAFT-PEDAL

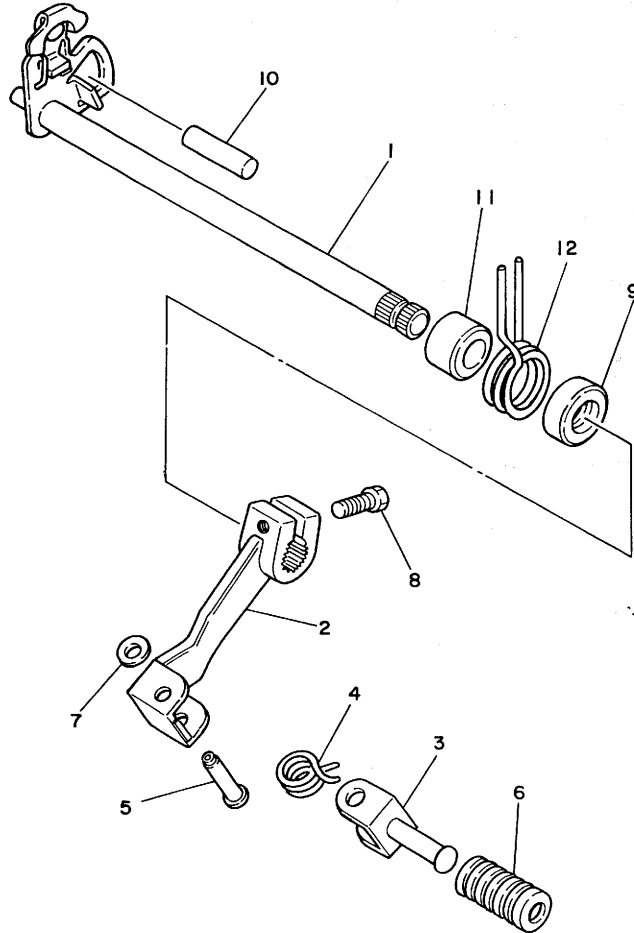

REF. NO.	PART NO.	DESCRIPTION	Q'TY	REMARKS
1	3R4-18101-01	SHIFT SHAFT ASSY	1	
2	4V4-18111-03	PEDAL, shift	1	
3	3R8-18162-00	PEDAL, shift	1	
4	90508-20415	SPRING, torsion	1	
5	90243-08017	PIN	1	
6	1W6-18113-00	COVER, shift Pedal	1	
7	90201-06042	WASHER, Plate	1	
8	97321-06020	BOLT	1	
9	93101-12004	OIL SEAL	1	
10	93608-25150	PIN, dowel	1	
11	90560-12171	SPACER	1	
12	90508-32374	SPRING, torsion	1	



C3

FIG. 14 FRAME. TOOL

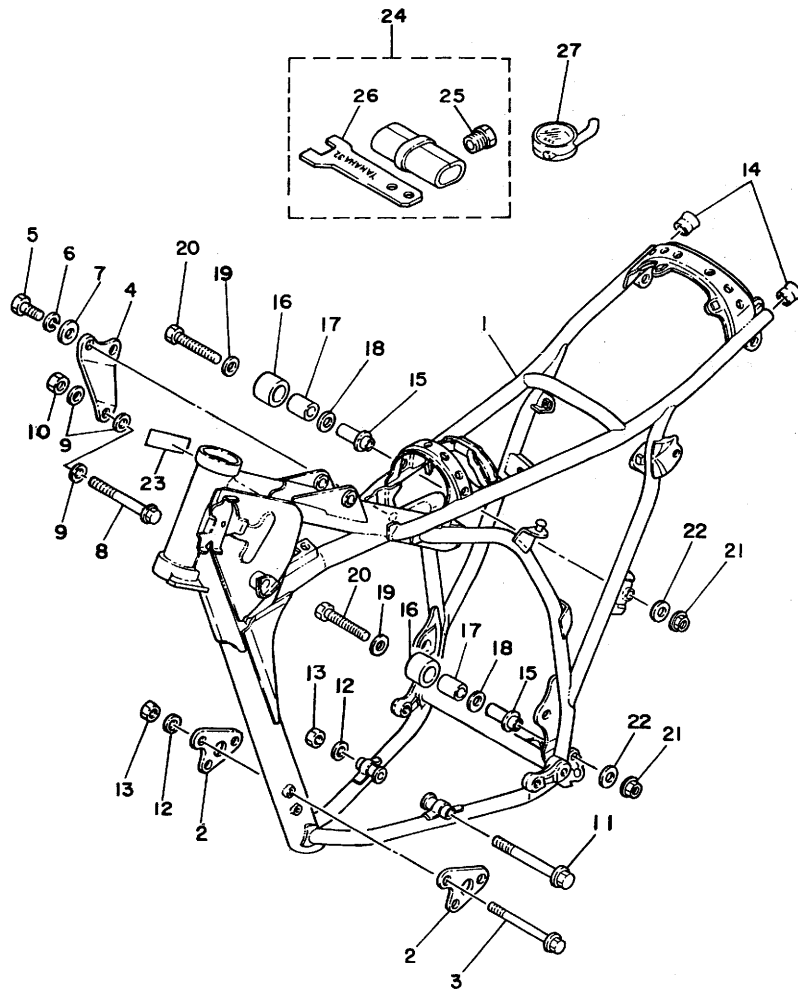

REF. NO.	PART NO.	DESCRIPTION	Q'TY	REMARKS
1	4V4-21110-00-33	FRAME COMP	1	yamaha black
2	3R4-21415-00	BRACKET, front uPPer 1	2	
3	95811-08075	BOLT, flanGe	3	
4	4V4-21425-00	BRACKET, rear uPPer 1	1	
5	97321-08025	BOLT	2	
6	92901-08100	WASHER, sPring	2	
7	92901-08600	WASHER, Plate	2	
8	95811-10055	BOLT, flanGe	1	
9	92901-10200	WASHER, Plain	3	
10	95601-10100	NUT, u	1	
11	95811-08165	BOLT, flanGe	1	
12	92901-08200	WASHER, Plain	4	
13	90185-08054	NUT, self-locking	4	
14	90339-13005	PLUG	2	
15	2K7-2148A-00	SHAFT	2	
16	4V4-22178-00	TENSIONER	2	
17	4V4-22184-00	BUSH	2	
18	90201-13202	WASHER, Plate	2	
19	90201-08113	WASHER, Plate	2	
20	97301-08055	BOLT	2	
21	95702-08300	NUT, nylon	2	
22	90201-08638	WASHER, Plate	2	
23	3R4-2139W-00	COVER	1	
24	2K7-28100-10	TOOL KIT	1	
25	2K7-85555-00	.PULLER, rotor	1	
26	1W1-28135-10	.SPANNER, sPecial	1	
27	2X4-2811A-00	GAUGE, air	1	



FIG. 15 FRONT FENDER•REAR FENDER

REF. NO.	PART NO.	DESCRIPTION	Q'TY	REMARKS
1	3R8-21511-01	FENDER, front	1	clean white
2	90201-06067	WASHER, Plate	4	
3	97302-06020	BOLT	4	
4	92902-06100	WASHER, sPring	4	
5	90209-06187	WASHER	4	
6	3R4-21611-10	FENDER, rear	1	clean white
7	97301-06015	BOLT	4	
8	92902-06100	WASHER, sPring	4	
9	90201-06067	WASHER, Plate	4	
10	3R4-21629-00	GUARD, mud	1	
11	97301-06015	BOLT	2	
12	92902-06100	WASHER, sPring	2	
13	90201-06067	WASHER, Plate	2	
14	1M1-21621-00	FLAP	1	
15	565-21746-00	SEAL, mud guard	1	

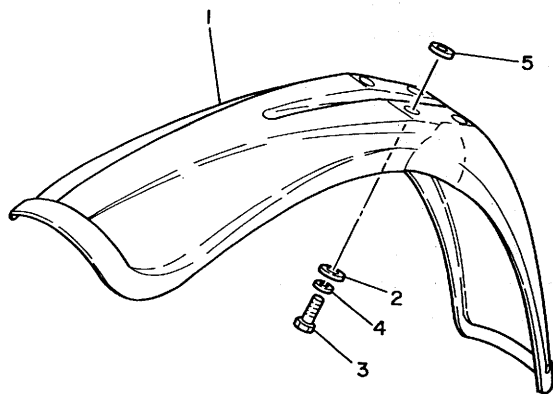
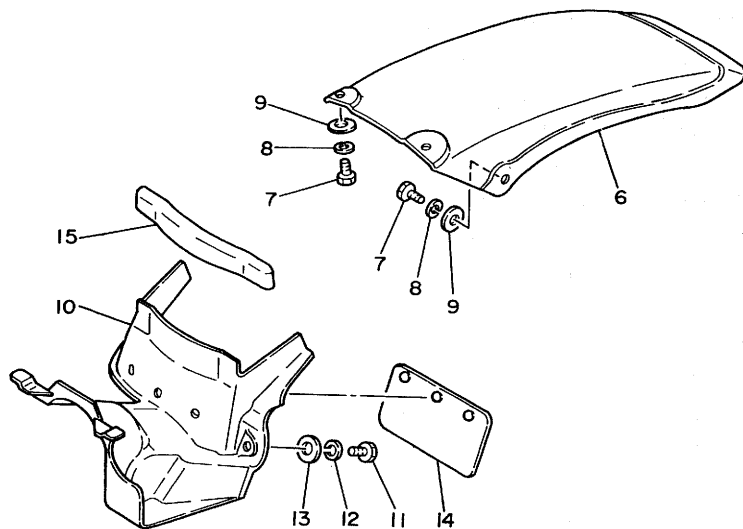

C5

FIG. 16 SIDE COVER

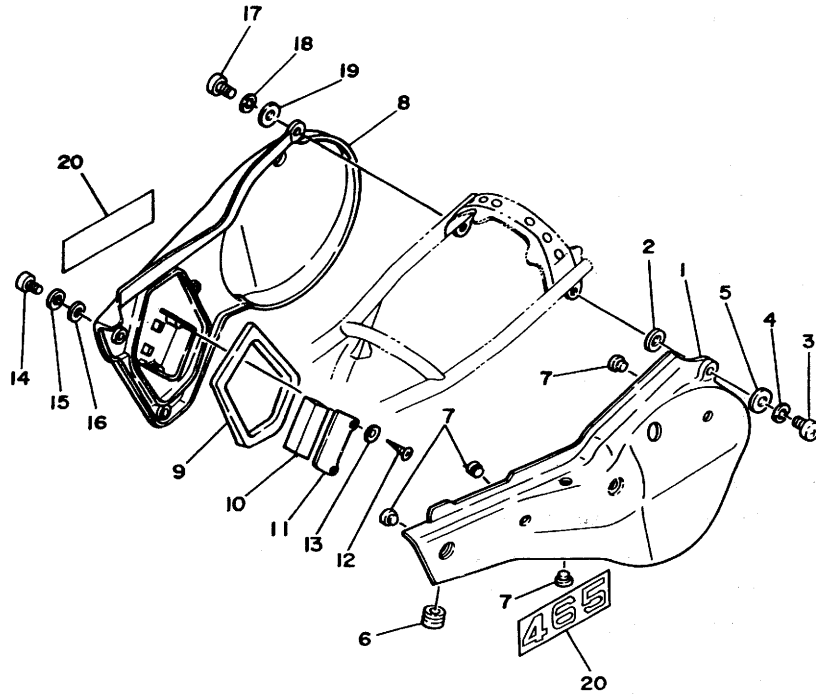

REF. NO.	PART NO.	DESCRIPTION	Q'TY	REMARKS
1	3R4-21711-10-98	COVER, side (L.H)	1	low gloss black / clean white
2	92902-08200	WASHER	2	
3	92501-06015	SCREW, Pan head	2	
4	92901-06100	WASHER, sPrinG	2	
5	90201-06571	WASHER, Plate	2	
6	90480-12053	GROMMET	1	
7	431-24181-00	DAMPER, locatinG 1	4	
8	3R4-21721-10-98	COVER, side (R.H)	1	low gloss black / clean white
9	4V4-21746-00	DAMPER	1	
10	3R4-21732-00	SEAL 1	1	
11	3R4-2172A-00	PANEL 1	1	
12	97702-40512	SCREW, taPPinG	2	
13	92902-04200	WASHER, Plain	2	
14	92501-06012	SCREW, Pan head	2	
15	92901-06100	WASHER, sPrinG	2	
16	92901-06200	WASHER, Plain	3	
17	92501-06015	SCREW, Pan head	2	
18	92901-06100	WASHER, sPrinG	2	
19	90201-06571	WASHER, Plate	1	
20	3R5-21737-00	EMBLEM	2	



FIG. 17 REAR ARM

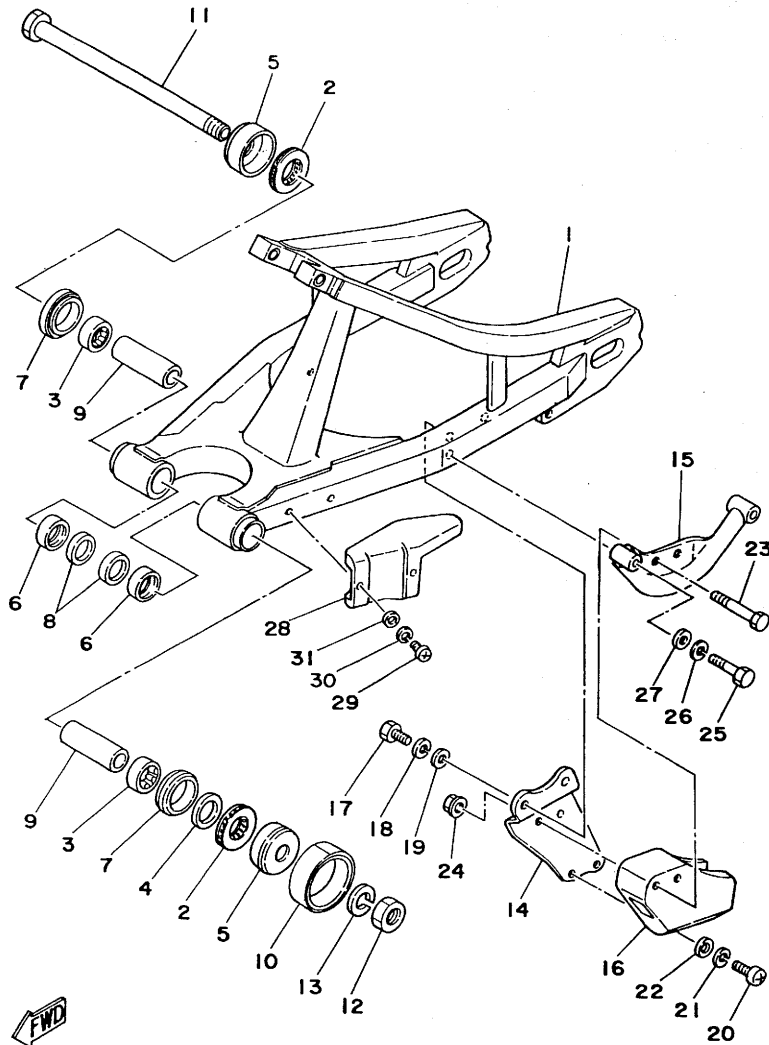

REF. NO.	PART NO.	DESCRIPTION	Q'TY	REMARKS
1	4V4-22110-00-35	REAR ARM COMP.	1	silver
2	93342-22208	BEARING	2	
3	93317-22214	BEARING, cylindrical	2	
4	648-45533-00-03	SHIM (0.3T)	1	UN
5	3R4-22129-00	COVER, thrust 2	2	
6	90386-22097	BUSH	2	
7	93108-35004	OIL SEAL	2	
8	93109-22018	OIL SEAL	2	
9	90380-16077	BUSH, solid	2	
10	431-22151-03	SEAL, Guard	1	
11	3R4-22141-00	SHAFT, Pivot	1	
12	90170-16111	NUT	1	
13	92901-16100	WASHER, sPring	1	
14	2X4-22179-00	ARM, tensioner	1	
15	3R5-22153-00	GUARD, chain	1	
16	2X4-22199-00	SUPPORT, chain	1	
17	97301-08016	BOLT	2	
18	92901-08100	WASHER, sPring	2	
19	92901-08600	WASHER, Plate	2	
20	92501-06020	SCREW, Pan head	2	
21	92901-06100	WASHER, sPring	2	
22	92901-06600	WASHER, Plate	2	
23	97301-06050	BOLT	2	
24	95702-06300	NUT, nylon	2	
25	97301-08035	BOLT	2	
26	92901-08100	WASHER, sPring	2	
27	92901-08600	WASHER, Plate	2	
28	3R4-22147-00	PROTECTOR, chain	1	

C7

FIG. 17 REAR ARM

REF. NO.	PART NO.	DESCRIPTION	Q'TY	REMARKS
29	98501-05010	SCREW, Pan head	2	
30	92901-05100	WASHER, sPrinG	2	
31	92901-05200	WASHER, Plain	2	

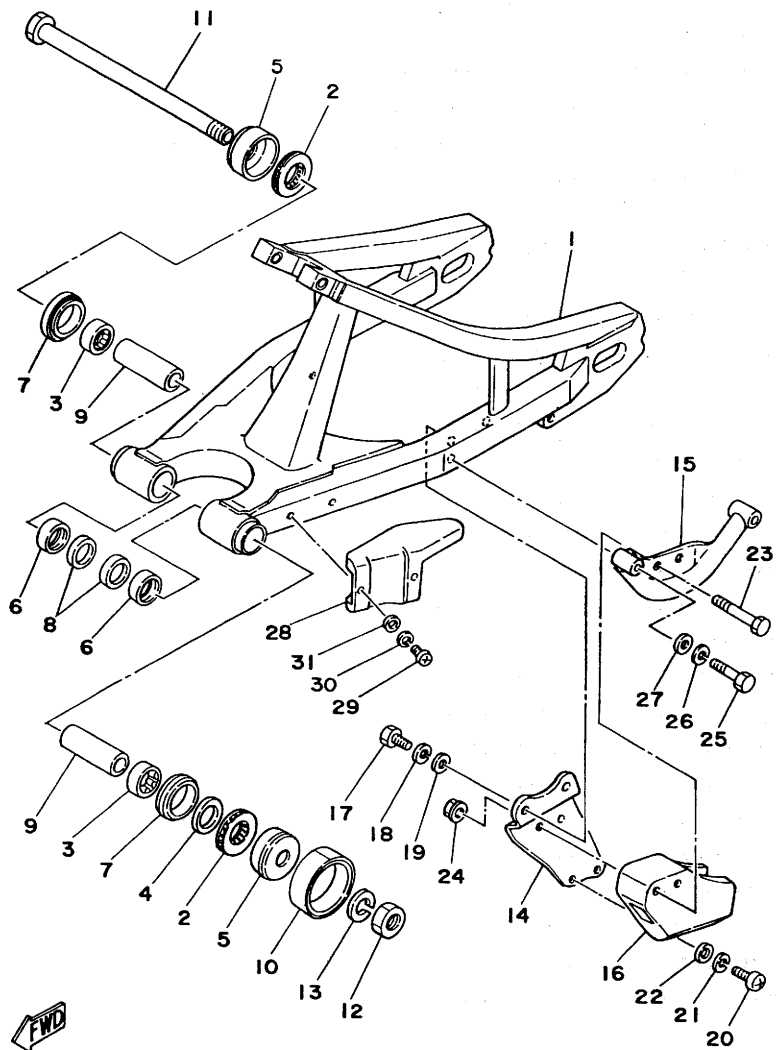

C8

FIG. 18 REAR SUSPENSION

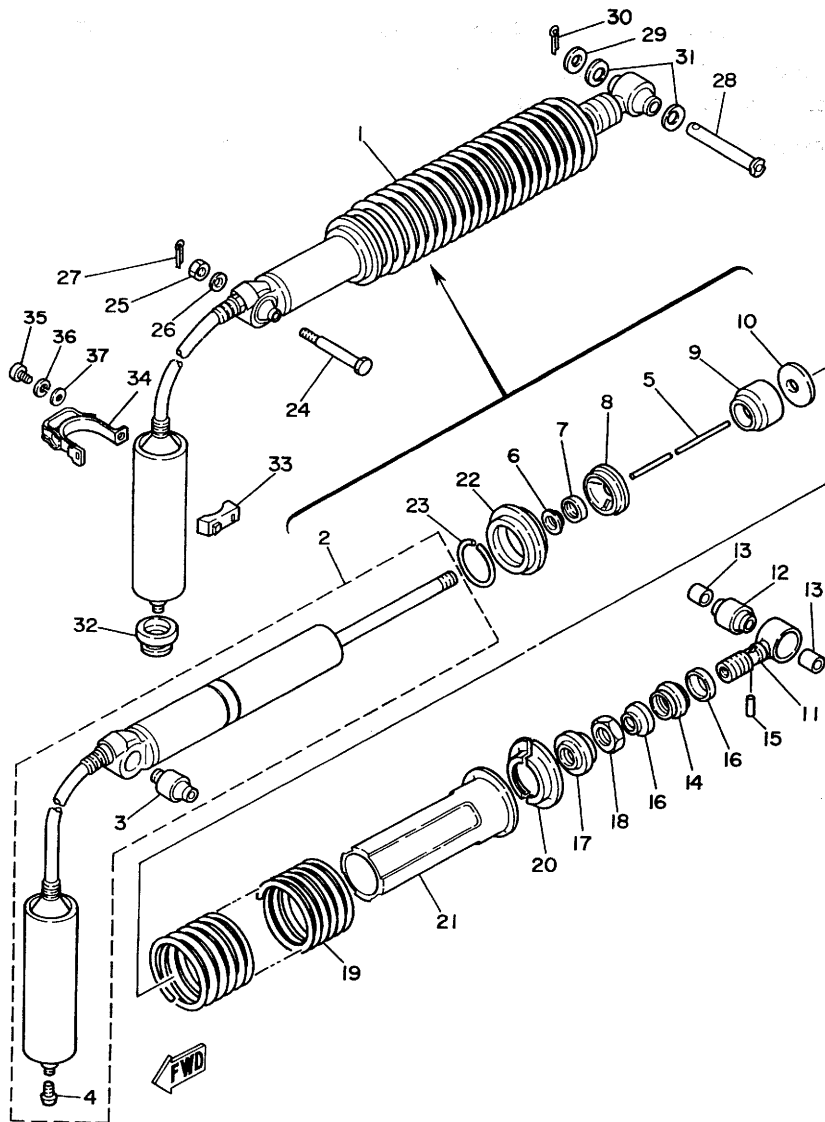

REF. NO.	PART NO.	DESCRIPTION	Q'TY	REMARKS
1	4V4-22210-10	SHOCK ABSORBER ASSY, rear	1	
2	4V4-22401-10	.DUMPER SUB ASSY	1	
3	1W1-22216-00	..BUSH, rear shock absorber	1	
4	98501-04005	..SCREW, Pan head	1	
5	4V4-22489-00	.ROD, Push	1	
6	3R4-22475-00	.SEAL, dust	1	
7	3R4-22473-00	.HOUSING, seal ring	1	
8	4L0-22472-00	.CAP, case	1	
9	2W6-22493-00	.BUMP, stoP	1	
10	3R4-22228-00	.SUPPRT, bumP stoP	1	
11	3R4-22409-00	.UPPER BRACKET SUB ASSY	1	
12	3R4-22226-00	.BUSH, shock absorber lower	1	
13	90380-12051	.BUSH, solid	2	
14	3R4-22497-00	.NUT, adjustinG	1	
15	93604-26132	.PIN, dowel	1	
16	3R4-22221-01	.COVER	2	
17	3R4-22213-00	.SEAT, sPrinG upper	1	
18	90170-20213	.NUT	1	
19	3R4-22212-10	.SPRING	1	soft (green)
20	3R4-22214-00	.GUIDE, sPrinG 1	2	
21	3R4-22224-00	.GUIDE, sPrinG 2	1	
22	3R4-22223-00	.SEAT, sPrinG lower	1	
23	93440-50078	.CIRCLIP	1	
24	90109-10550	BOLT	1	
25	95302-10700	NUT	1	
26	92902-10600	WASHER, Plate	1	
27	91401-20025	PIN, cotter	1	
28	90240-12074	PIN, clevis	1	

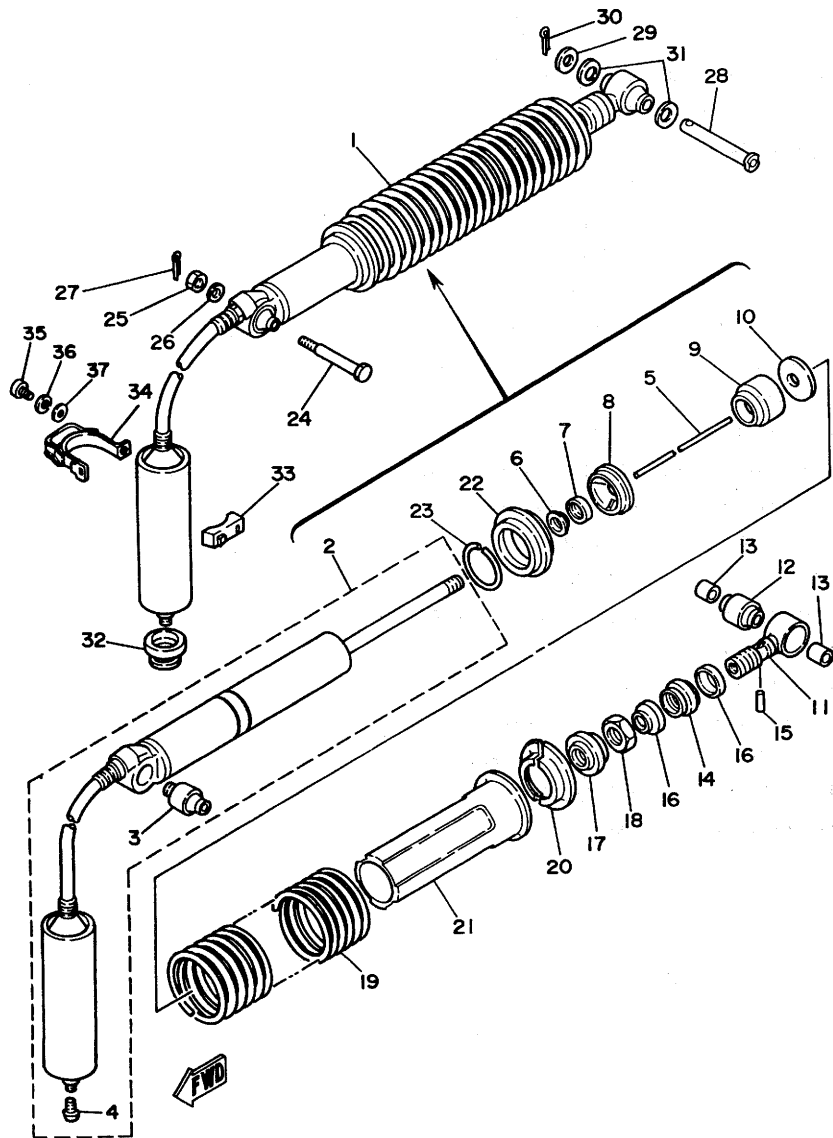
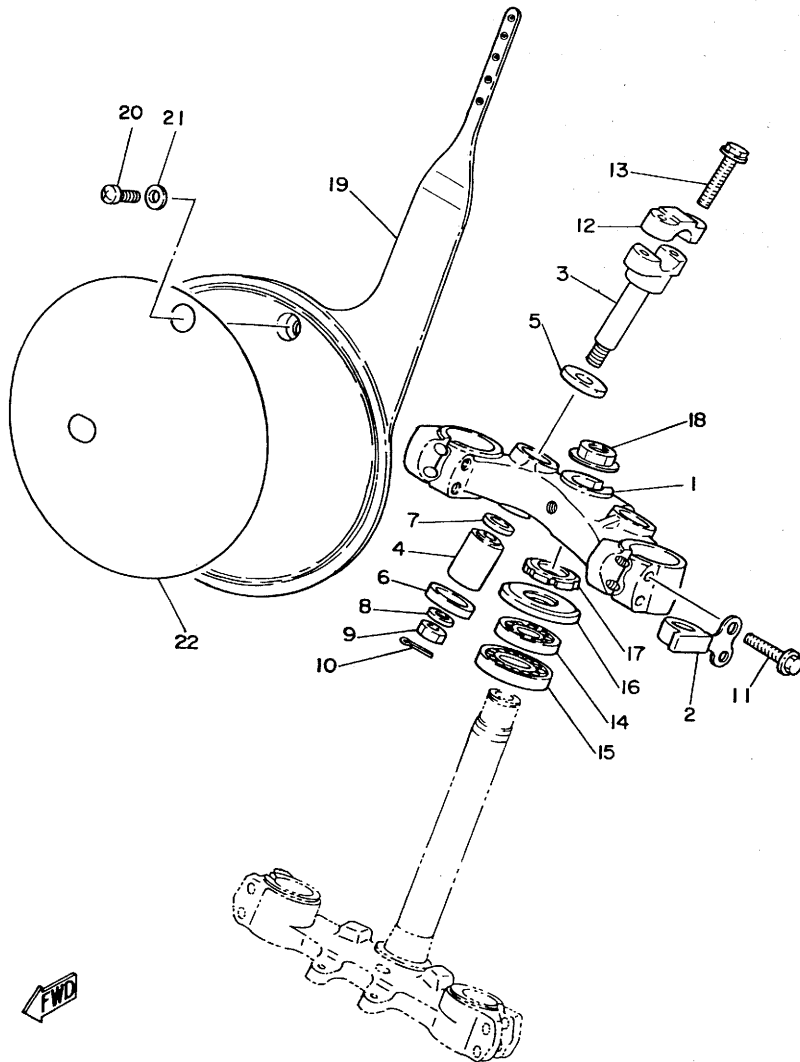

FIG. 18 REAR SUSPENSION

REF. NO.	PART NO.	DESCRIPTION	Q'TY	REMARKS
29	92901-12600	WASHER, Plate	1	
30	91401-30022	PIN, cotter	1	
31	1W1-22128-00	COVER, thrust 1	2	
32	90480-22263	GROMMET	1	
33	3R4-22261-00	DAMPER, sub tank	1	
34	4V4-22262-01	HOLDER, sub tank	1	
35	92502-06016	SCREW, Pan head	1	
36	92902-06100	WASHER, sPrin&	1	
37	92902-06600	WASHER	1	

FIG. 19 STEERING



REF. NO.	PART NO.	DESCRIPTION	Q'TY	REMARKS
1	4V4-23435-00-98	CROWN, handle	1	low gloss black
2	3R4-23317-00	HOLDER, cable	1	
3	1E6-23442-00	HOLDER, handle lower	2	
4	307-22123-00	BUSH 1	2	
5	90201-123E8	WASHER, Plate	2	
6	90201-104A6	WASHER, Plate	2	
7	90387-121E8	COLLAR	2	
8	90202-14077	WASHER, Plate	2	
9	90185-10037	NUT, self-locking	2	
10	91402-20018	PIN, cotter	2	
11	95821-08040	BOLT, flange	4	
12	1E6-23441-00-98	HOLDER, handle upper	2	low gloss black
13	95821-08035	BOLT, flange	4	
14	93332-00001	BEARING	1	
15	93332-00008	BEARING	1	
16	1W1-23416-00	COVER, ball race 2	1	
17	90179-25033	NUT	1	
18	90179-22330	NUT	1	
19	4V4-23485-10	PLATE, number	1	white
20	97801-06012	SCREW, Pan head	1	
21	90201-06067	WASHER, Plate	1	
22	4V4-21782-10	EMBLEM 2	1	

C11

FIG. 20 FRONT FORK

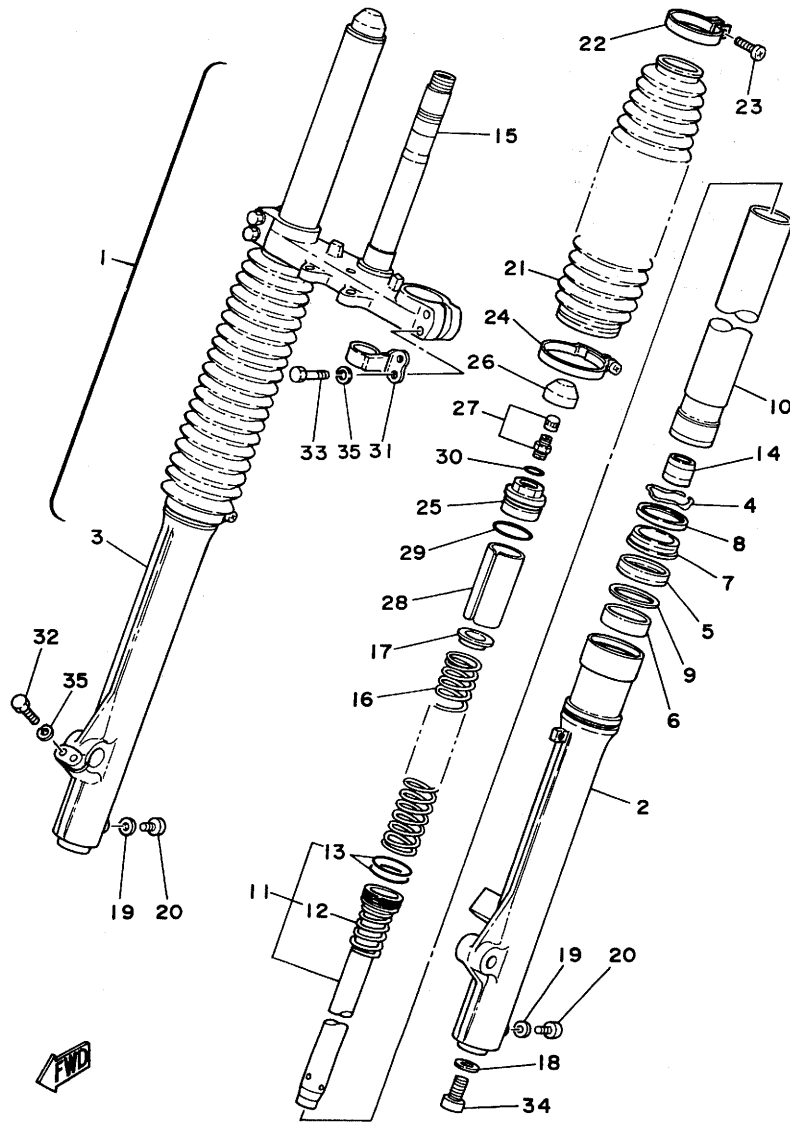

REF. NO.	PART NO.	DESCRIPTION	Q'TY	REMARKS
1	4V4-23101-L1	FRONT FORK ASSY	1	
2	4V4-23126-L1	•TUBE, outer 1	1	
3	4V4-23136-L1	•TUBE, outer 2	1	
4	4V4-23153-L0	•RING, snap	2	
5	4V4-23145-L0	•OIL SEAL	2	
6	4V4-23125-L0	•METAL, slide 1	2	
7	4V4-23144-L0	•SEAL, dust	2	
8	4V4-23148-L0	•COVER, dust seal	2	
9	4V4-23146-L0	•WASHER, oil seal	2	
10	4V4-23110-L0	•INNER TUBE COMP.1	2	
11	4V4-23170-L0	•CYLINDER COMP., front fork	2	
12	4V4-23152-L0	••SPRING, sub	2	
13	4V4-23188-L0	••O-RING	4	
14	4V4-23173-L0	•SPINDLE, taPer	2	
15	4V4-23340-L0-33	•UNDER BRACKET COMP.	1	yamaha black
16	4V4-23141-L0	•SPRING, front fork	2	
17	4V4-23142-L0	•SEAT, sPring upper	2	
18	4V4-23158-L0	•GASKET	2	
19	122-23129-00	•GASKET, drain Plug	2	
20	122-23119-01	•PLUG, drain	2	
21	4V4-23191-L0	•BODT	2	
22	4V4-23192-L0	•BAND	2	
23	4V4-23194-L0	•SCREW, boot band	2	
24	4V4-23489-L0	•BAND	2	
25	4V4-23111-L0	•BOLT, caP	2	
26	1W1-23185-L0	•CAP, front fork	2	
27	4V4-23190-L0	•AIR VALVE COMP.	2	
28	4V4-23118-L0	•SPACER	2	

FIG. 20 FRONT FORK

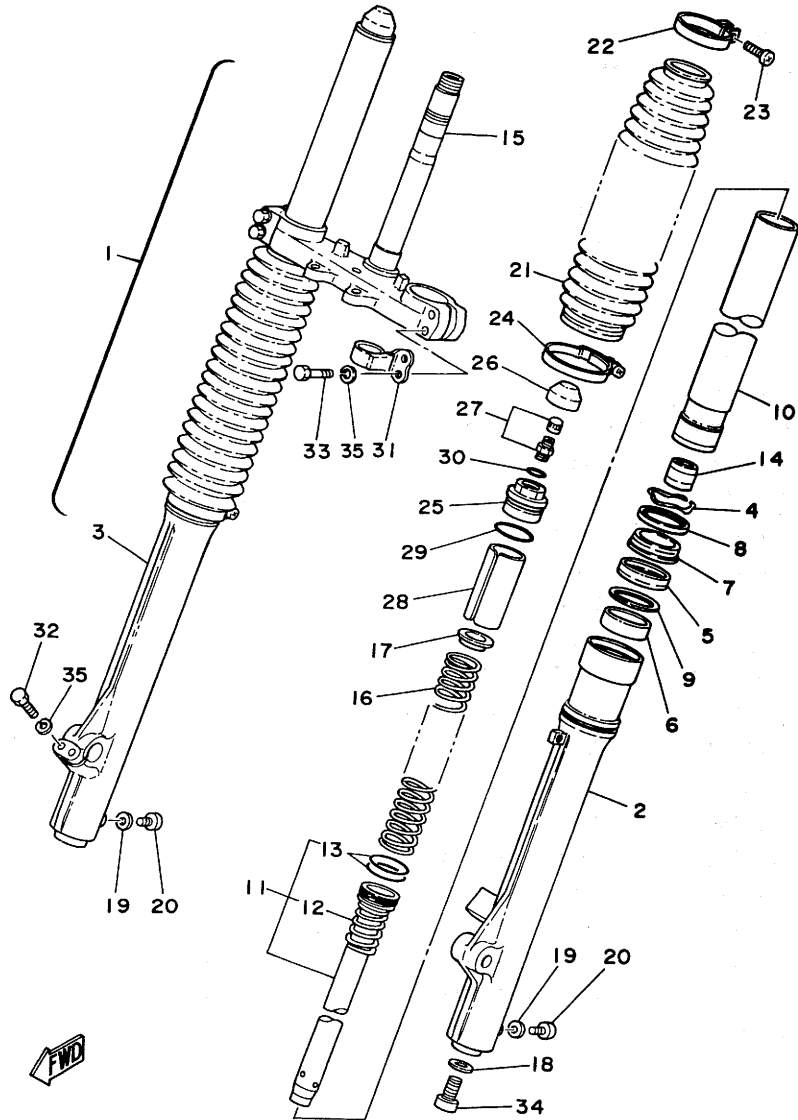

REF. NO.	PART NO.	DESCRIPTION	Q'TY	REMARKS
29	4V4-23188-L0	•O-RING	2	
30	3J2-23147-00	•O-RING	2	
31	3R4-23389-00	•GUIDE, cable	1	
32	1W4-23128-L0	•BOLT, axle holder	2	
33	4V4-23346-L0	•BOLT 1	4	
34	4V4-23181-L0	•BOLT, hexagon socket head	2	
35	92901-08100	•WASHER, sPring	6	

C13

FIG. 21 FUEL TANK

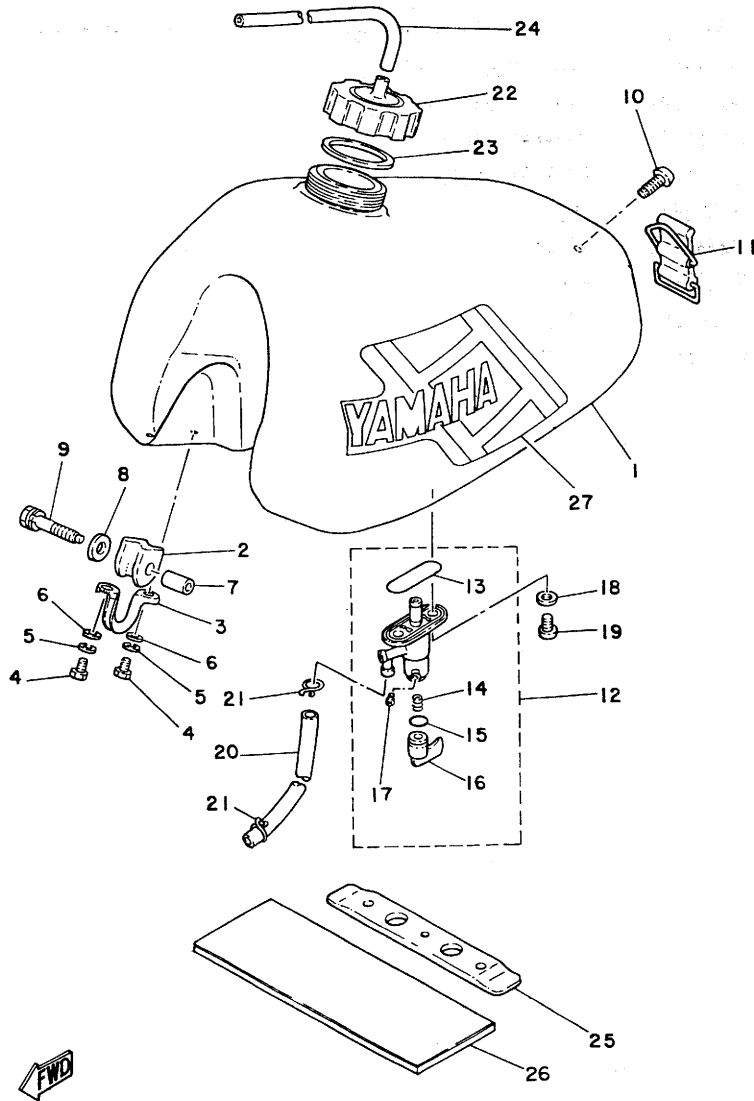

REF. NO.	PART NO.	DESCRIPTION	Q'TY	REMARKS
1	4V4-24110-10	FUEL TANK COMP.	1	clean white
2	1W1-24182-01	DAMPER, locatin& 2	2	
3	1W1-24144-01	HOLDER, damPer	2	
4	97301-06012	BOLT	4	
5	92901-06100	WASHER, sPring	4	
6	92901-06600	WASHER, Plate	4	
7	90387-07393	COLLAR	2	
8	90201-06407	WASHER, Plate	2	
9	90119-06022	BOLT, with washer	2	
10	98902-06018	SCREW, bind	1	
11	3R3-24173-00	BAND, tank fittin& 1	1	
12	2K5-24500-00	FUEL COCK ASSY 1	1	
13	214-24512-00	.GASKET	1	
14	1A0-24529-01	.SPRING	1	
15	1A0-24512-00	.O-RING	1	
16	1A0-24524-01	.LEVER, cock	1	
17	619-24535-00	.SCREW, lever fittin&	1	
18	90202-06010	WASHER, Plate	2	
19	90149-06011	SCREW	2	
20	90445-11182	HOSE	1	
21	90467-10008	CLIP	2	
22	1W1-24611-00	BODY, caP	1	
23	1W1-24612-00	GASKET, caP	1	
24	90445-09300	HOSE	1	
25	3R4-24181-00	DAMPER, locatin& 1	1	
26	1W1-24183-00	DAMPER, locatin& 3	1	
27	4V4-24240-19	GRAPHIC SET	1	

FIG. 22 SEAT

REF. NO.	PART NO.	DESCRIPTION	Q'TY	REMARKS
1	3R4-W2473-00	SEMI-DOUBLE SEAT ASSY	1	
2	3R4-24771-00	COVER, semi-double seat	1	
3	1M1-24748-00	BRACKET, seat	1	
4	1W1-24738-00	BRACKET, seat	2	
5	90101-06304	BOLT	6	
6	509-24724-00	DAMPER, seat	2	
7	97302-06035	BOLT	2	
8	95601-06100	NUT, u	2	
9	92902-06200	WASHER	2	

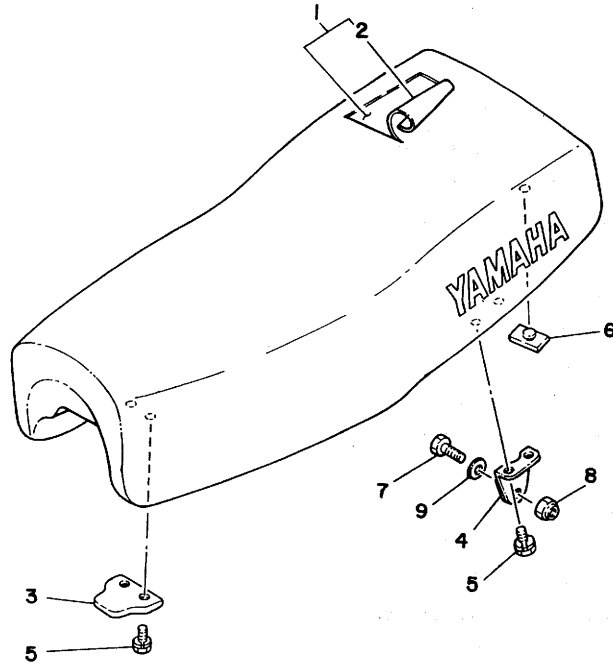

C15

FIG. 23 FRONT WHEEL

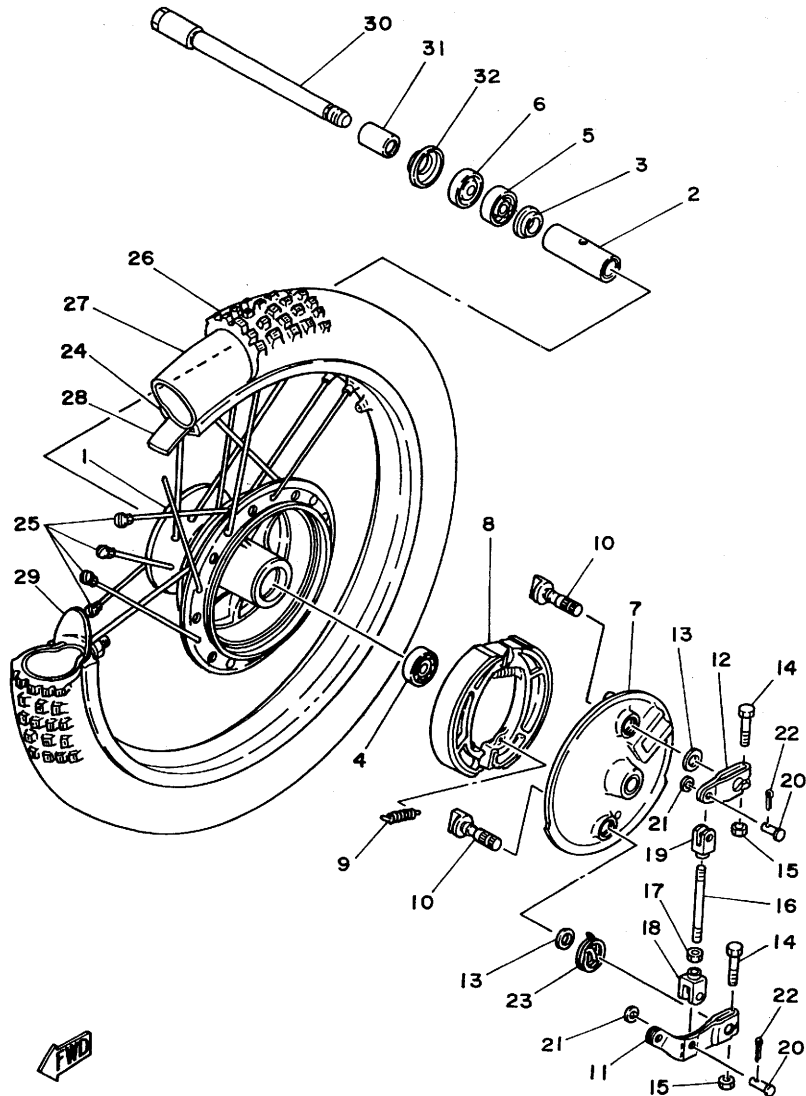

REF. NO.	PART NO.	DESCRIPTION	Q'TY	REMARKS
1	1K7-25111-10-98	HUB, front	1	low gloss black
2	90560-15116	SPACER	1	
3	146-25116-00	FLANGE, sPacer 2	1	
4	93306-20203	BEARING (B6202RS)	1	
5	93306-20205	BEARING (B6202)	1	
6	93102-20009	OIL SEAL	1	
7	3R5-25121-00-98	PLATE, brake shoe	1	low gloss black
8	3R5-25130-00	BRAKE SHOE COMP.	2	
9	90506-16036	SPRING, tension	2	
10	322-25151-00	CAMSHAFT	2	
11	3R5-25155-00	LEVER, camshaft 1	1	
12	3R5-25156-00	LEVER, camshaft 2	1	
13	137-25159-00	SEAL, camshaft	2	
14	90101-06278	BOLT	2	
15	95301-06600	NUT	2	
16	3R5-25161-00	ROD, connecting	1	
17	95301-06700	NUT	1	
18	3R5-25163-00	END, rod 1	1	
19	3R5-25164-00	END, rod 2	1	
20	90240-06006	PIN, clevis	2	
21	92901-06200	WASHER, Plain	2	
22	91401-20012	PIN, cotter	2	
23	90508-20425	SPRING, torsion	1	
24	94416-21234	RIM (1.60-21)	1	
25	2W6-25104-01	SPOKE SET, front	1	
26	94130-21659	TIRE (3.00-21)	1	
27	94227-21123	TUBE (2.75-21)	1	
28	94330-21084	BAND, rim (3.00-21)	1	

FIG. 23 FRONT WHEEL

REF. NO.	PART NO.	DESCRIPTION	Q'TY	REMARKS
29	2J5-25394-00	SPACER, bead	1	
30	3R4-25181-00	AXLE, wheel	1	
31	90387-15535	COLLAR	1	
32	322-25118-00	COVER, hub dust	1	

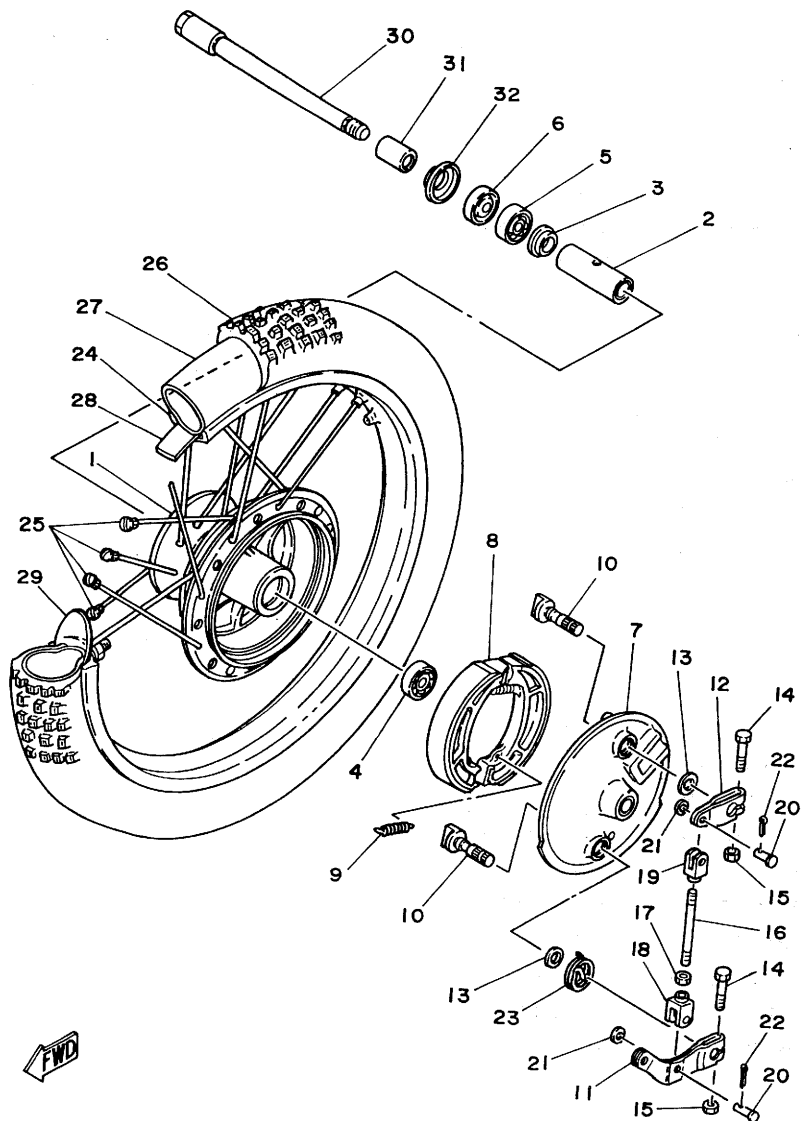

D3

FIG. 24 REAR WHEEL

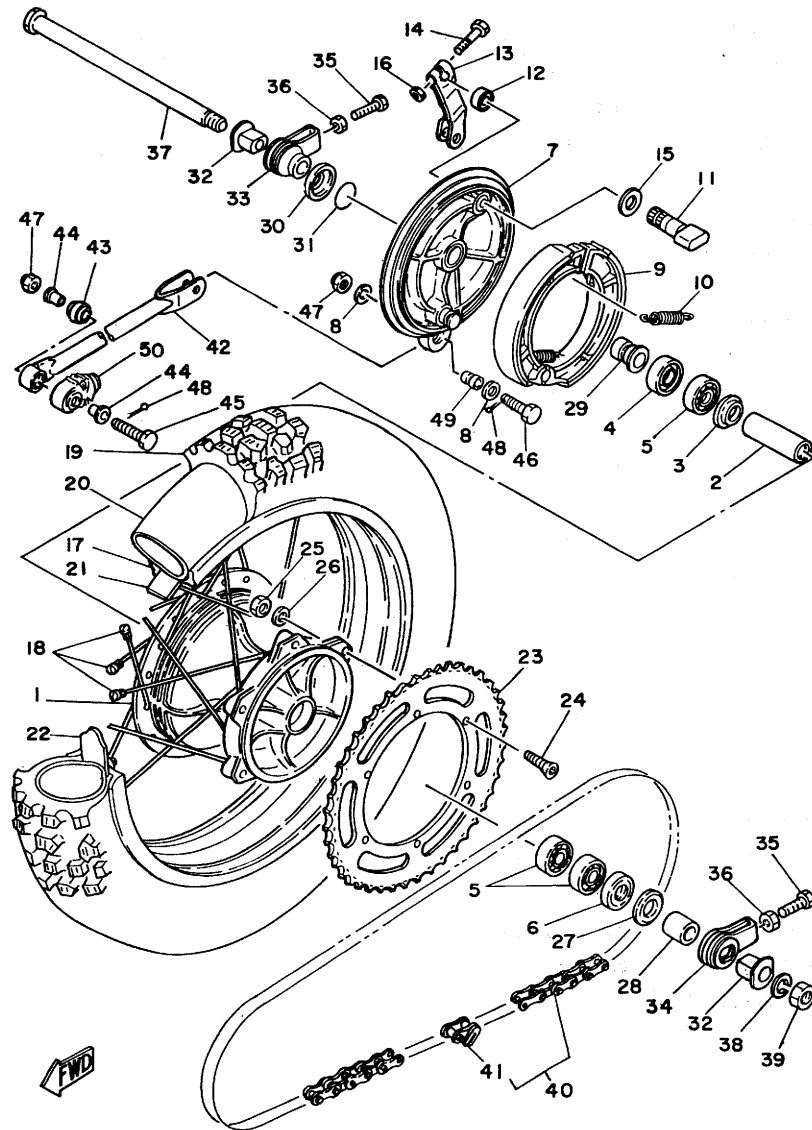

REF. NO.	PART NO.	DESCRIPTION	Q'TY	REMARKS
1	4V4-25311-00-98	HUB, rear	1	low gloss black
2	4V4-25317-00	SPACER, bearing	1	
3	4V4-25315-00	FLANGE, spacer	1	
4	93306-00418	BEARING	1	
5	93306-00406	BEARING (B6004Z)	3	
6	93102-28022	OIL SEAL	1	
7	4V4-25321-00-98	PLATE, brake shoe	1	low gloss black
8	93104-11056	OIL SEAL	2	
9	4V4-25330-00	BRAKE SHOE COMP.	2	
10	90507-20002	SPRING, tension	2	
11	1E2-25151-00	CAMSHAFT	1	
12	148-25359-00	SEAL, camshaft	1	
13	4V4-25355-00	LEVER, camshaft	1	
14	90101-06278	BOLT	1	
15	148-25353-00	SHIM, camshaft	1	
16	95301-06600	NUT	1	
17	94425-18280	RIM (2.50-18)	1	
18	4V4-25304-00	SPOKE SET, rear	1	
19	94151-18662	TIRE (5.10-18)	1	
20	94251-18150	TUBE (5.10-18)	1	
21	94340-18086	BAND, rim (4.00-18)	1	
22	2X5-25394-00	SPACER, bead	2	
23	3R4-25446-00	SPROCKET, driven (46T)	1	STD except europe
	3R4-25450-00	SPROCKET, driven (50T)	1	STD for europe
	3R4-25444-00	SPROCKET, driven (44T)	1	AP
	3R4-25448-00	SPROCKET, driven (48T)	1	AP
	3R4-25452-00	SPROCKET, driven (52T)	1	AP
24	90110-08038	BOLT, hexagon socket head	6	

FIG. 24 REAR WHEEL

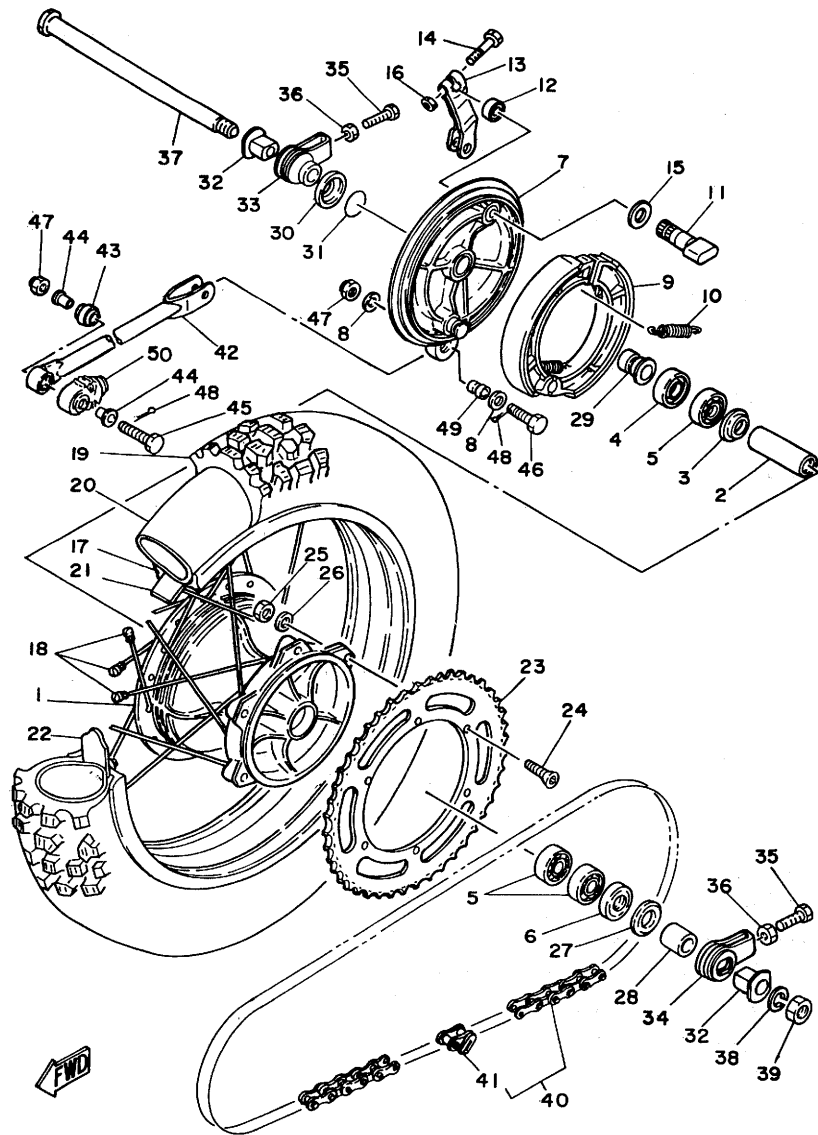

REF. NO.	PART NO.	DESCRIPTION	Q'TY	REMARKS
25	90185-08054	NUT, self-locking	6	
26	90201-081A6	WASHER, Plate	6	
27	4V4-25367-00	COVER, hub dust	1	
28	90387-201E4	COLLAR	1	
29	90387-201E3	COLLAR	1	
30	4V4-25327-00	COVER, Plate	1	
31	93210-33481	O-RING	1	
32	90381-20036	BUSH, solid	2	
33	4V4-25389-00	PULLER, chain 2	1	
34	4V4-25388-00	PULLER, chain 1	1	
35	90101-08475	BOLT	2	
36	95301-08700	NUT	2	
37	4V4-25381-00	AXLE, wheel	1	
38	92901-18100	WASHER, sPring	1	
39	90170-18275	NUT	1	
40	94585-20112	CHAIN, drive (DID520DS 112L)	1	for europe
	94585-20108	CHAIN, drive (DID520DS 108L)	1	except europe
41	94685-20001	JOINT, chain	1	
42	3R5-25371-01	BAR, tension	1	
43	93399-99905	BEARING	1	
44	90387-082E1	COLLAR	2	
45	90102-08034	BOLT, with hole	1	
46	90102-08043	BOLT, with hole	1	
47	95611-08100	NUT, u	2	
48	91401-20015	PIN, cotter	2	
49	90387-08699	COLLAR	1	
50	4V4-25335-00	CAP	1	

FIG. 25 HANDLEBAR.CABLE

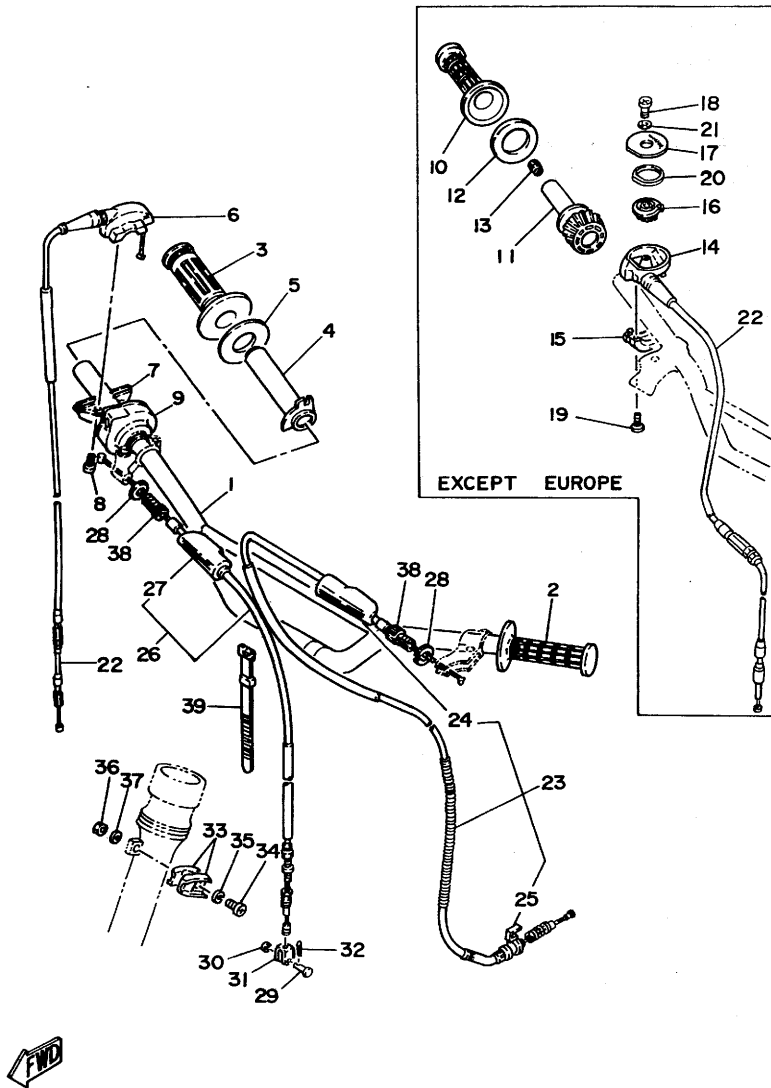

REF. NO.	PART NO.	DESCRIPTION	Q'TY	REMARKS
1	4V2-26111-00 3R4	HANDLEBAR	1	
2	4V4-26241-00	GRIP (L.H)	1	
3	3R9-26242-00	GRIP (R.H)	1	
4	431-26243-00	TUBE, throttle guide	1	}
5	1W1-26249-00	RING, leaf	1	
6	431-26281-01-98	CAP, grip upper	1	
7	431-26282-01-98	CAP, grip lower	1	for europe
8	98501-05016	SCREW, Pan head	2	}
9	3R8-26287-00	COVER, cap grip	1	
10	4V4-26242-00	GRIP (R.H)	1	
11	4V4-26243-00	TUBE, throttle guide	1	}
12	1W1-26249-00	RING, leaf	1	
13	668-82535-00	GROMMET	1	
14	4V4-26281-00	CAP, grip upper	1	}
15	4V4-26282-00	CAP, grip lower	1	
16	4V4-2628E-00	GEAR, bevel	1	
17	4V4-2628F-00	CAP, gear	1	except europe
18	98906-05010	SCREW, bind	1	}
19	98501-05016	SCREW, Pan head	2	
20	4V4-2628G-00	PACKING	1	
21	90430-05009	GASKET	1	}
22	2K8-26311-01	CABLE, throttle 1	1	
	4V4-26311-00	CABLE, throttle 1	1	except europe
23	4V4-26335-00	CABLE, clutch	1	
24	382-26372-01	.COVER, handle lever	1	
25	3R4-26393-00	.HOLDER	1	
26	3R8-26341-00	CABLE, brake	1	
27	382-26372-01	.COVER, handle lever	1	

FIG. 25 HANDLEBAR CABLE

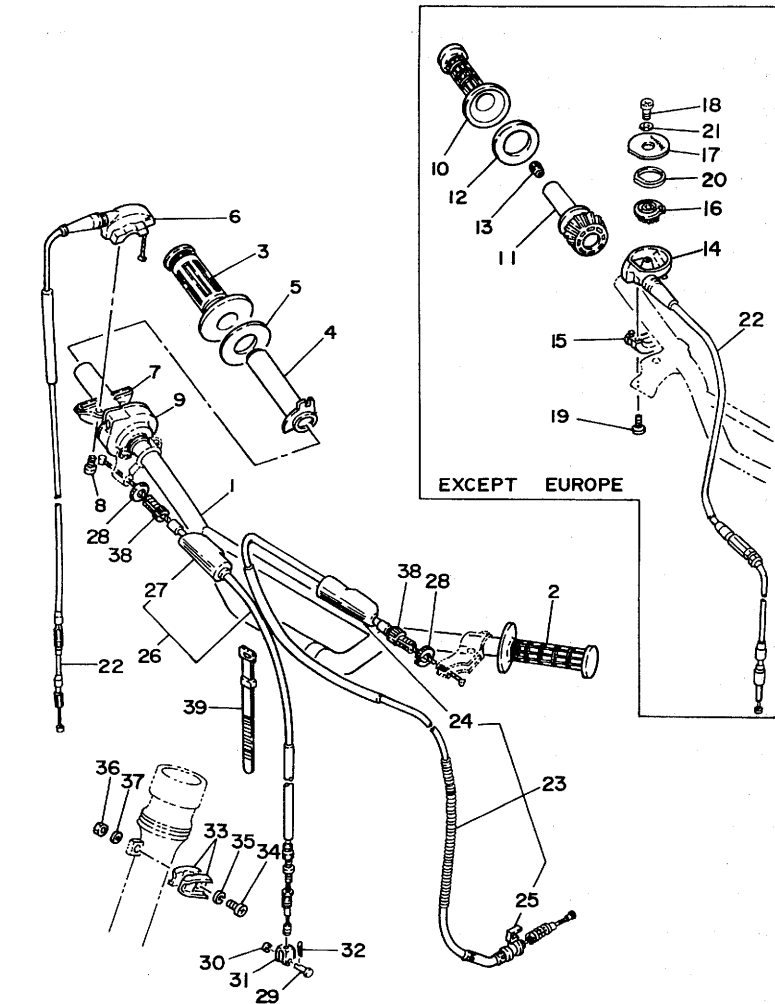

REF. NO.	PART NO.	DESCRIPTION	Q'TY	REMARKS
28	90179-08148	NUT	2	
29	90240-08012	PIN, clevis	1	
30	90201-08083	WASHER, Plate	1	
31	156-26347-00	JOINT, cable	1	
32	91401-20012	PIN, cotter	1	
33	90462-14055	CLAMP	2	
34	92501-06025	SCREW, Pan head	1	
35	92901-06100	WASHER, sPring	1	
36	95301-06600	NUT	1	
37	92901-06600	WASHER, Plate	1	
38	90123-08046	BOLT	2	
39	437-83936-10	BAND, switch cord	1	

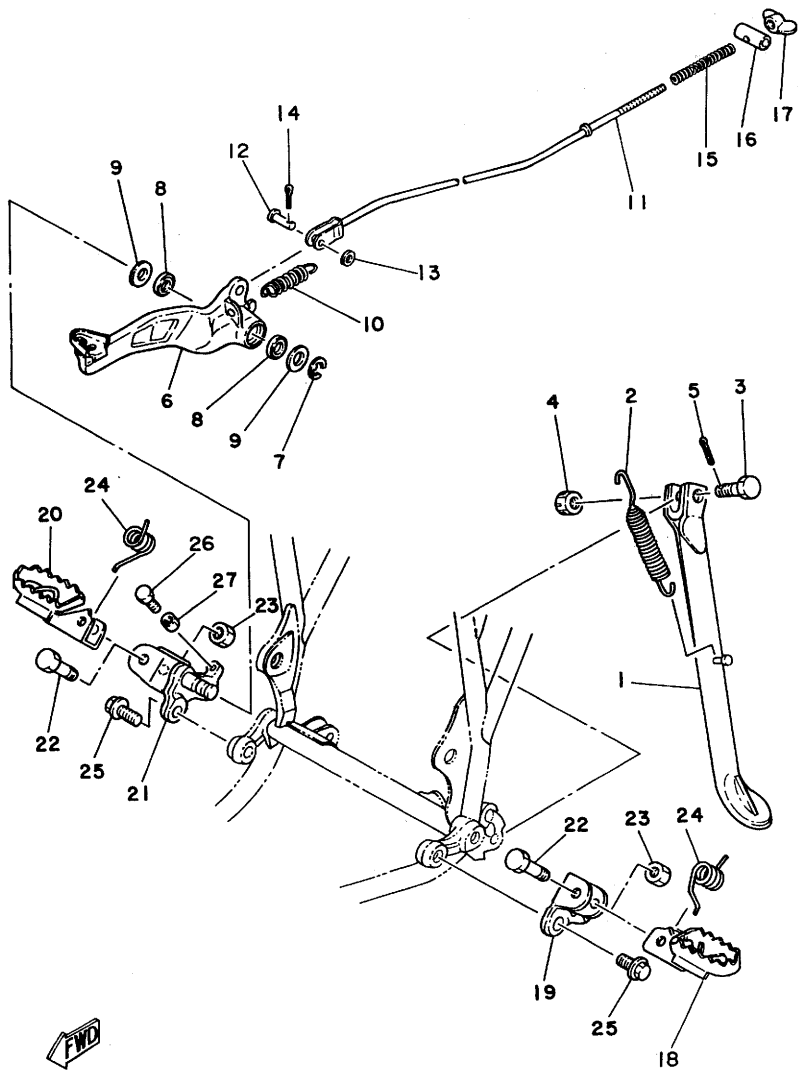

FIG. 26 STAND.FOOTREST

REF. NO.	PART NO.	DESCRIPTION	Q'TY	REMARKS
1	3R4-27311-00-33	STAND, side	1	yamaha black
2	90507-29008	SPRING, tension	1	
3	90102-10006	BOLT, with hole	1	
4	95302-10900	NUT, slotted	1	
5	91401-20025	PIN, cotter	1	
6	4V4-27200-00	PEDAL, brake	1	
7	93430-10015	CIRCLIP	1	
8	93109-14021	OIL SEAL	2	
9	90201-14536	WASHER, Plate	2	
10	90506-20192	SPRING, tension	1	
11	2X4-27231-01	RDD, brake	1	
12	90240-06040	PIN, clevis	1	
13	92901-06200	WASHER, Plain	1	
14	91401-20012	PIN, cotter	1	
15	90501-10245	SPRING, compression	1	
16	90249-12008	PIN	1	
17	90175-06013	NUT, wing	1	
18	4V4-27411-00	FOOTREST 1	1	
19	4V4-27412-00	BRACKET, footrest 1	1	
20	4V4-27421-00	FOOTREST 2	1	
21	4V4-27422-00	BRACKET, footrest 2	1	
22	90101-08428	BOLT	2	
23	95601-08100	NUT, u	2	
24	90508-20023	SPRING, torsion	2	
25	90105-12096	BOLT, washer based	4	
26	97301-06020	BOLT	1	
27	95301-06700	NUT	1	

D8

FIG. 27 ELECTRICAL 1

REF. NO.	PART NO.	DESCRIPTION	Q'TY	REMARKS
1	1M2-82310-40	IGNITION COIL ASSY	1	
2	92501-06025	SCREW, Pan head	2	
3	92901-06100	WASHER, sPrinG	2	
4	90462-05005	CLAMP	1	
5	3R0-82370-20	PLUG CAP ASSY	1	UR
	8E7-82370-11	PLUG CAP ASSY	1	UR with noise suppressor
6	437-83936-00	BAND, switch cord	2	

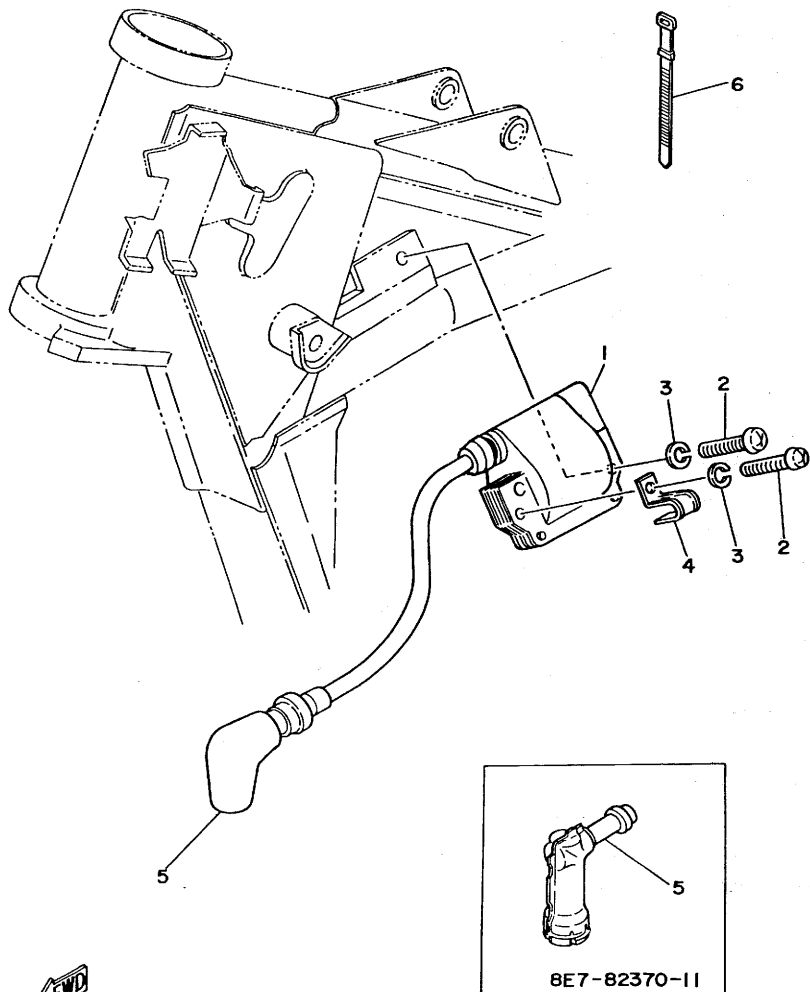

D9

FIG. 28 HANDLE SWITCH-LEVER

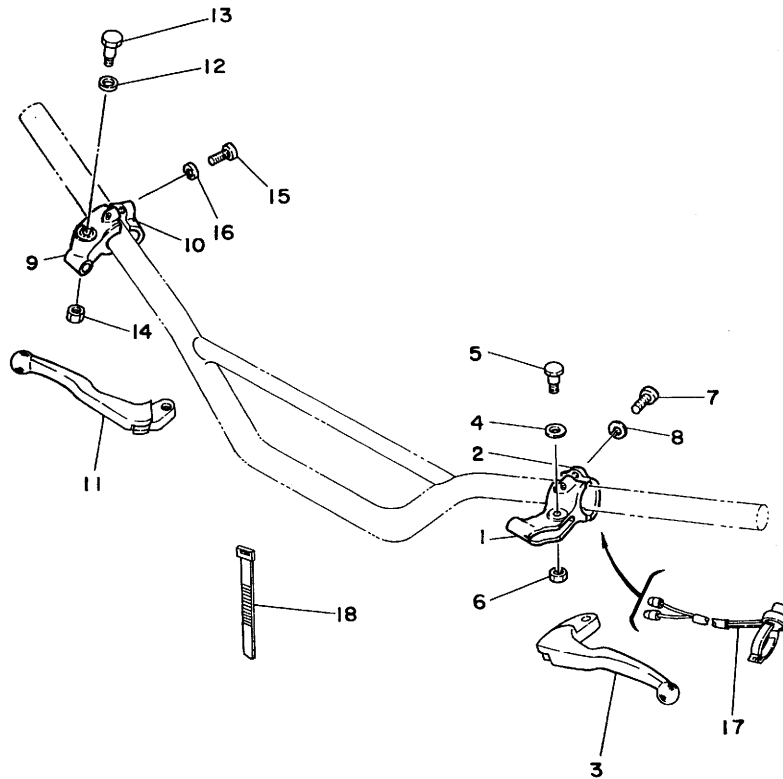

REF. NO.	PART NO.	DESCRIPTION	Q'TY	REMARKS
1	4V4-82911-00	HOLDER, lever 1	1	
2	4V4-82913-00	HOLDER, lever lower 1	1	
3	3M2-83912-00	LEVER 1	1	
4	90201-08083	WASHER, Plate	1	
5	90109-06410	BOLT	1	
6	95601-06100	NUT, u	1	
7	98506-05020	SCREW, Pan head	2	
8	92906-05100	WASHER, sPring	2	
9	4V4-82921-00	HOLDER, lever 2	1	
10	4V4-82913-00	HOLDER, lever lower 1	1	
11	3M2-83922-00	LEVER 2	1	
12	90201-08083	WASHER, Plate	1	
13	90109-06410	BOLT	1	
14	95601-06100	NUT, u	1	
15	98506-05020	SCREW, Pan head	2	
16	92906-05100	WASHER, sPring	2	
17	3R4-83976-00	SWITCH, handle 1	1	
18	437-83936-00	BAND, switch cord	2	

ALTERNATE PARTS

1/20/11

FIG. 29 ALTERNATE (CHASSIS)

REF. NO.	PART NO.	DESCRIPTION	Q'TY	REMARKS
1	4V4-22212-10	SPRING	1	UR soft (pink)
	3R4-22212-00	SPRING	1	UR hard (no painted)
2	4V4-23141-10	SPRING, front fork (K=0.275)	2	UR soft
	4V4-23141-20	SPRING, front fork (K=0.31)	2	UR hard

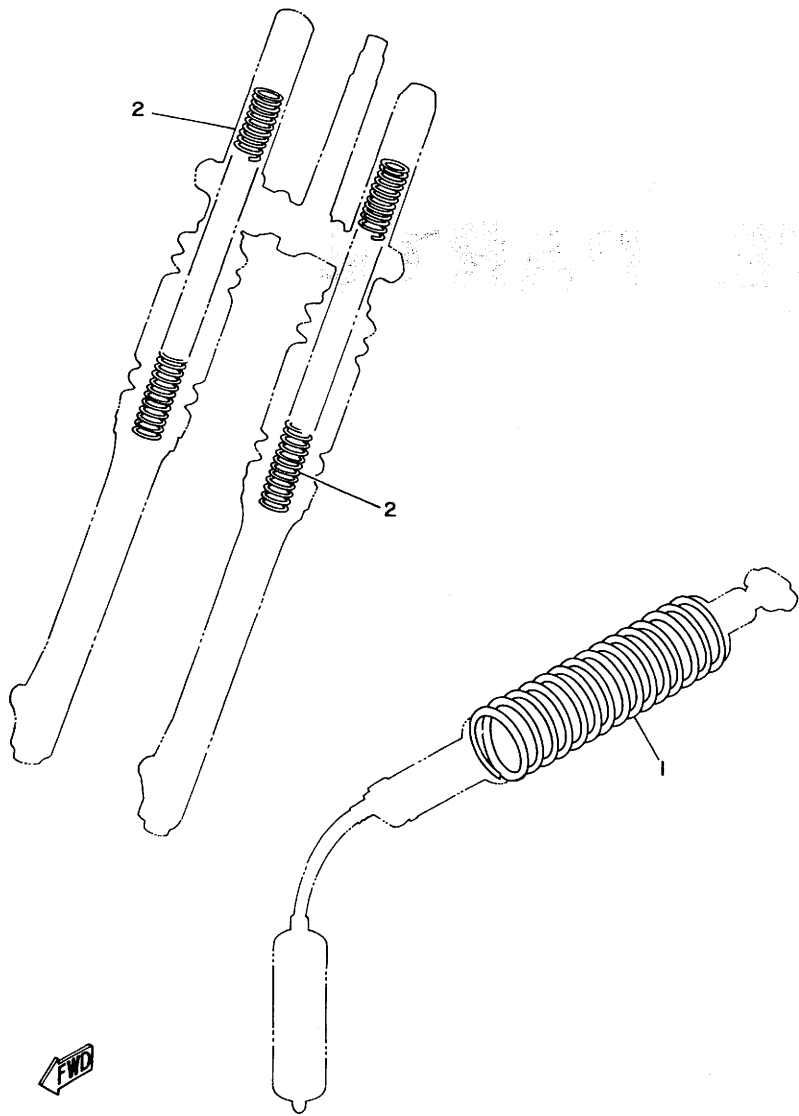

D11

REPAIR KIT

FIG. 30 REPAIR KIT

REF. NO.	PART NO.	DESCRIPTION	Q'TY	REMARKS
1	3R5-11630-00	PISTON ASSY (STD)	1	
2	3R5-11631-00-94	•PISTON (STD)	1	UR
	3R5-11631-00-96	•PISTON (STD)	1	UR
3	3R5-11601-00	•PISTON RING SET (STD)	1	
4	275-11633-00	•PIN, Piston	1	
5	93450-19052	•CIRCLIP	2	
6	3R5-11630-10	PISTON ASSY (1ST O/S)	1	
7	3R5-11635-00	•PISTON (1ST O/S 0.25MM)	1	
8	3R5-11601-10	•PISTON RING SET (1ST O/S)	1	
9	275-11633-00	•PIN, Piston	1	
10	93450-19052	•CIRCLIP	2	
11	3R5-11630-20	PISTON ASSY (2ND O/S)	1	
12	3R5-11636-00	•PISTON (2ND O/S 0.50MM)	1	
13	3R5-11601-20	•PISTON RING SET (2ND O/S)	1	
14	275-11633-00	•PIN, Piston	1	
15	93450-19052	•CIRCLIP	2	
16	3R5-11630-30	PISTON ASSY (3RD O/S)	1	
17	3R5-11637-00	•PISTON (3RD O/S 0.75MM)	1	
18	3R5-11601-30	•PISTON RING SET (3RD O/S)	1	
19	275-11633-00	•PIN, Piston	1	
20	93450-19052	•CIRCLIP	2	
21	3R5-11630-40	PISTON ASSY (4TH O/S)	1	
22	3R5-11638-00	•PISTON (4TH O/S 1.00MM)	1	
23	3R5-11601-40	•PISTON RING SET (4TH O/S)	1	
24	275-11633-00	•PIN, Piston	1	
25	93450-19052	•CIRCLIP	2	
26	3R5-11650-00	CONNECTING ROD ASSY	1	
27	3R5-11651-00	•ROD, connectin	1	

FIG. 30 REPAIR KIT

REF. NO.	PART NO.	DESCRIPTION	Q'TY	REMARKS
28	3R5-11681-00	•PIN, crank 1	1	
29	90209-25085	•WASHER	2	
30	93310-42541	•BEARING, cylindrical	1	
31	93310-418E9	•BEARING, cylindrical	1	
32	4V4-W0001-00	GASKET KIT	1	
33	3R5-11181-00	•GASKET, cylinder head 1	1	
34	3R5-11351-00	•GASKET, cylinder	1	
35	2K7-13621-00	•GASKET, valve seat	1	
36	363-14184-00	•GASKET, float chamber	1	
37	3R4-14613-00	•GASKET, exhaust Pipe	1	
38	4V4-15451-00	•GASKET, crankcase cover	1	
39	3R4-15462-00	•GASKET, crankcase cover 3	1	
40	93210-14104	•O-RING	1	
41	90430-06016	•GASKET	1	
42	90430-12038	•GASKET	1	
43	93210-29282	•O-RING	1	
44	2K7-W0003-00	OIL SEAL KIT	1	
45	93103-30092	•OIL SEAL	1	
46	93103-40091	•OIL SEAL	1	
47	93102-17004	•OIL SEAL	1	
48	93102-32136	•OIL SEAL	1	
49	93101-12004	•OIL SEAL	1	
50	93109-20014	•OIL SEAL	1	

INDEX

NUMERICAL INDEX

PART NO.	REF. NO.	PART NO.	REF. NO.	PART NO.	REF. NO.
4V4-W0001-00	30-32	3R5-11651-00	2-10	310-14197-00	5-14
2K7-W0003-00	30-44		30-27	737-14261-00	5-39
4V4-W1441-00	4-11	3R5-11681-00	2- 9	509-14274-00	5-28
3R4-W1442-01	4-14		30-28	1W4-14457-00	4-12
3R4-W2473-00	22- 1			3R4-14458-00	4-15
3R5-11111-00	1- 1	3R4-13565-00	4- 7	4V4-14459-00	4-16
3R5-11181-00	1- 2	3R5-13610-00	4- 1	4V4-14484-00	4-21
	30-33	3R5-13613-00	4- 2	4V4-14499-00	4-22
4V4-11311-00	1- 6	2X5-13616-00	4- 3	4V4-14610-00	6- 1
3R5-11351-00	1- 7	2K7-13621-00	4- 6	3R4-14613-00	6- 2
	30-34		30-35		30-37
3R5-11400-00	2- 6	4V4-14101-00	5- 1	3R5-14619-00	6- 9
3R5-11412-00	2- 7	510-14112-30	5-27	565-14747-00	6-12
3R5-11422-00	2- 8	510-14115-00	5-31	4V4-14753-00	6-11
3R5-11601-00	2- 2	239-14116-16	5-33	565-14771-00	6-16
	30- 3	2A0-14122-00	5-25	3R4-14781-02	6- 4
3R5-11601-10	2- 2	152-14123-00	5-23	3R5-15111-00	7- 1
	30- 8	363-14131-00	5-17	3R4-15113-00	7-17
3R5-11601-20	2- 2	127-14134-00	5-22	4V4-15118-00	7-15
	30-13	156-14135-00	5-41	3R5-15121-02	7- 9
3R5-11601-30	2- 2	509-14136-00	5-35	1G8-15362-00	8-11
	30-18	164-14137-00	5-34	3R4-15381-00	7-13
3R5-11601-40	2- 2	363-14137-00	5-21	3R4-15383-00	7- 6
	30-23	353-14138-00	5-37	3R5-15411-00	8- 1
3R5-11630-00	30- 1	510-14141-52	5- 5	3R4-15421-00	8- 4
3R5-11630-10	30- 6	193-14142-45	5- 4	3R4-15431-01	8- 8
3R5-11630-20	30-11	137-14143-76	5- 6	4V4-15451-00	8- 2
3R5-11630-30	30-16	137-14143-78	5- 6		30-38
3R5-11630-40	30-21	137-14143-80	5- 6	3R4-15462-00	8- 9
3R5-11631-00-94	2- 1	3R4-14146-00	5-29		30-39
	30- 2	558-14147-00	5-32	2K7-15618-00	9-17
3R5-11631-00-96	2- 1	8F2-14147-00	5-18	4V3-15620-00	9-11
	30- 2	2X8-14153-00	5-30	4V3-15621-00	9-12
275-11633-00	2- 3	3R4-14155-00	5-20	3R4-15641-00	9- 2
	30- 4	3R4-14158-00	5-24	3R4-15651-00	9- 7
	30- 9	127-14161-00	5-19	3R4-15660-00	9- 1
	30-14	802-14161-00	5-26	3R4-15664-00	9- 6
	30-19	737-14171-00	5-42	3R5-16111-00	10- 1
	30-24	637-14173-00	5-40	3R4-16150-00	10- 7
3R5-11635-00	2- 1	152-14174-00	5-36	2K7-16154-00	10-15
	30- 7	3R4-14181-16	5- 2	2K7-16181-00	10-14
3R5-11636-00	2- 1	363-14184-00	5- 3	3R5-16300-00	10- 6
	30-12		30-36	383-16321-00	10-11
3R5-11637-00	2- 1	2N7-14185-00	5- 7	168-16325-00	10-10
	30-17	537-14186-00	5- 9	1M1-16351-00	10- 9
3R5-11638-00	2- 1	363-14190-35	5- 8	3R4-16356-00	10-18
	30-22	239-14195-00	5-10	3R5-16357-00	10-24
3R5-11650-00	30-26	2K7-14197-00	5-11	3R4-16371-00	10- 8

NUMERICAL INDEX

PART NO.	REF. NO.	PART NO.	REF. NO.	PART NO.	REF. NO.
4V4-16380-00	10-29	1W1-22128-00	18-31	4V4-23148-L0	20- 8
3R5-17121-00	11- 9	3R4-22129-00	17- 5	4V4-23152-L0	20-12
3R5-17131-00	11- 6	3R4-22141-00	17-11	4V4-23153-L0	20- 4
3R5-17141-00	11- 3	3R4-22147-00	17-28	4V4-23158-L0	20-18
3R5-17151-00	11- 8	431-22151-03	17-10	4V4-23170-L0	20-11
3R5-17211-01	11-20	3R5-22153-00	17-15	4V4-23173-L0	20-14
3R5-17221-00	11-13	4V4-22178-00	14-16	4V4-23181-L0	20-34
3R5-17231-01	11-18	2X4-22179-00	17-14	1W1-23185-L0	20-26
2X5-17241-00	11-19	4V4-22184-00	14-17	4V4-23188-L0	20-13
3R5-17251-00	11-16	2X4-22199-00	17-16		20-29
3R5-17411-00	11- 1	4V4-22210-10	18- 1	4V4-23190-L0	20-27
3R5-17421-00	11-12	3R4-22212-00	29- 1	4V4-23191-L0	20-21
1W4-17461-30	11-27	3R4-22212-10	18-19	4V4-23192-L0	20-22
1W4-17461-40	11-27	4V4-22212-10	29- 1	4V4-23194-L0	20-23
1W4-17461-50	11-27	3R4-22213-00	18-17	3R4-23317-00	19- 2
3R4-18101-01	13- 1	3R4-22214-00	18-20	4V4-23340-L0-33	20-15
4V4-18111-03	13- 2	1W1-22216-00	18- 3	4V4-23346-L0	20-33
1W6-18113-00	13- 6	3R4-22221-01	18-16	3R4-23389-00	20-31
3R4-18140-00	12- 7	3R4-22223-00	18-22	1W1-23416-00	19-16
3R8-18162-00	13- 3	3R4-22224-00	18-21	4V4-23435-00-98	19- 1
1W1-18177-00	12- 9	3R4-22226-00	18-12	1E6-23441-00-98	19-12
3R4-18185-00	12- 2	3R4-22228-00	18-10	1E6-23442-00	19- 3
3R5-18511-00	12-10	3R4-22261-00	18-33	4V4-23485-10	19-19
3R5-18512-00	12-11	4V4-22262-01	18-34	4V4-23489-L0	20-24
3R5-18513-00	12-12	4V4-22401-10	18- 2	4V4-24110-10	21- 1
4V4-18531-00	12-14	3R4-22409-00	18-11	1W1-24144-01	21- 3
4V4-18535-00	12-15	4L0-22472-00	18- 8	3R3-24173-00	21-11
3R5-18540-01	12- 1	3R4-22473-00	18- 7	3R4-24181-00	21-25
3R4-18561-00	12- 3	3R4-22475-00	18- 6	431-24181-00	16- 7
4V4-21110-00-33	14- 1	4V4-22489-00	18- 5	1W1-24182-01	21- 2
3R4-2139W-00	14-23	2W6-22493-00	18- 9	1W1-24183-00	21-26
3R4-21415-00	14- 2	3R4-22497-00	18-14	156-24186-00	6-14
4V4-21425-00	14- 4	4V4-23101-L1	20- 1	4V4-24240-19	21-27
2K7-2148A-00	14-15	4V4-23110-L0	20-10	2K5-24500-00	21-12
3R8-21511-01	15- 1	4V4-23111-L0	20-25	1A0-24512-00	21-15
3R4-21611-10	15- 6	4V4-23118-L0	20-28	214-24512-00	21-13
1M1-21621-00	15-14	122-23119-01	20-20	1A0-24524-01	21-16
3R4-21629-00	15-10	4V4-23125-L0	20- 6	1A0-24529-01	21-14
3R4-21711-10-98	16- 1	4V4-23126-L1	20- 2	619-24535-00	21-17
3R4-2172A-00	16-11	1W4-23128-L0	20-32	1W1-24611-00	21-22
3R4-21721-10-98	16- 8	122-23129-00	20-19	1W1-24612-00	21-23
3R4-21732-00	16-10	4V4-23136-L1	20- 3	509-24724-00	22- 6
3R5-21737-00	16-20	4V4-23141-L0	20-16	1W1-24738-00	22- 4
4V4-21746-00	16- 9	4V4-23141-10	29- 2	1M1-24748-00	22- 3
565-21746-00	15-15	4V4-23141-20	29- 2	3R4-24771-00	22- 2
4V4-21782-10	19-22	4V4-23142-L0	20-17	2W6-25104-01	23-25
4V4-22110-00-35	17- 1	4V4-23144-L0	20- 7	1K7-25111-10-98	23- 1
307-22123-00	19- 4	4V4-23145-L0	20- 5	146-25116-00	23- 3
		4V4-23146-L0	20- 9		
		3J2-23147-00	20-30		

NUMERICAL INDEX

PART NO.	REF. NO.	PART NO.	REF. NO.
322-25118-00	23-32	431-26281-01-98	25- 6
3R5-25121-00-98	23- 7	4V4-26282-00	25-15
3R5-25130-00	23- 8	431-26282-01-98	25- 7
1E2-25151-00	24-11	3R8-26287-00	25- 9
322-25151-00	23-10	2K8-26311-01	25-22
3R5-25155-00	23-11	4V4-26311-00	25-22
3R5-25156-00	23-12	4V4-26335-00	25-23
137-25159-00	23-13	3R8-26341-00	25-26
3R5-25161-00	23-16	156-26347-00	25-31
3R5-25163-00	23-18	382-26372-01	25-24
3R5-25164-00	23-19		25-27
3R4-25181-00	23-30	3R4-26393-00	25-25
4V4-25304-00	24-18	4V4-27200-00	26- 6
4V4-25311-00-98	24- 1	2X4-27231-01	26-11
4V4-25315-00	24- 3	3R4-27311-00-33	26- 1
4V4-25317-00	24- 2	4V4-27411-00	26-18
4V4-25321-00-98	24- 7	4V4-27412-00	26-19
4V4-25327-00	24-30	4V4-27421-00	26-20
4V4-25330-00	24- 9	4V4-27422-00	26-21
4V4-25335-00	24-50	2K7-28100-10	14-24
148-25353-00	24-15	2X4-2811A-00	14-27
4V4-25355-00	24-13	1W1-28135-10	14-26
148-25359-00	24-12	648-45533-00-03	17- 4
4V4-25367-00	24-27	104-81328-20	3- 9
		110-81345-21	3-14
		116-82131-00	3-21
3R5-25371-01	24-42	1M2-82310-40	27- 1
4V4-25381-00	24-37	3R0-82370-20	27- 5
4V4-25388-00	24-34	8E7-82370-11	27- 5
4V4-25389-00	24-33	668-82535-00	25-13
2J5-25394-00	23-29	4V4-82911-00	28- 1
2X5-25394-00	24-22	4V4-82913-00	28- 2
3R4-25444-00	24-23		28-10
3R4-25446-00	24-23		28- 9
3R4-25448-00	24-23	4V4-82921-00	28- 9
3R4-25450-00	24-23	3M2-83912-00	28- 3
3R4-25452-00	24-23	3M2-83922-00	28-11
4V2-26111-00	25- 1	256-83936-00	3-23
4V4-26241-00	25- 2	437-83936-00	27- 6
3R9-26242-00	25- 3		28-18
4V4-26242-00	25-10	437-83936-10	25-39
4V4-26243-00	25-11	3R4-83976-00	28-17
431-26243-00	25- 4	3R5-85500-20	3- 1
1W1-26249-00	25- 5	3R5-85509-20	3- 3
	25-12	3R5-85511-20	3- 4
4V4-2628E-00	25-16	3R5-85512-20	3- 5
4V4-2628F-00	25-17	3R5-85515-20	3- 8
4V4-2628G-00	25-20	1W2-85516-20	3- 7
4V4-26281-00	25-14	3R5-85540-20	3-20
		3R5-85547-00	3-22

PART NO.	REF. NO.	PART NO.	REF. NO.
3R5-85550-20	3- 2	90101-06304	22- 5
2K7-85555-00	14-25	90101-08428	26-22
2W6-85550-20	3- 6	90101-08475	24-35
90101-06278	23-14	90102-08034	24-45
	24-14	90102-08043	24-46
	22- 5	90102-10006	26- 3
	26-22	90105-12096	26-25
	24-35	90109-06410	28- 5
	24-45		28-13
	19- 5	90109-06551	6-17
	3-18	90109-08512	6-15
	14-18	90109-10550	18-24
	26- 9	90110-08038	24-24
	9-15	90116-08321	1- 4
	10-27	90116-12315	1- 8
	9- 8	90116-12316	1- 9
	11-10	90119-06022	21- 9
	11-21	90123-08046	25-38
	9- 4	90149-06011	21-19
	11- 4	90149-08143	10-20
	11-14	90159-06016	10-13
	21-18	90170-12067	3-17
	19- 8	90170-16111	17-12
	15- 5	90170-18089	10- 4
	11- 7	90170-18275	24-39
	11-17	90170-20213	18-18
	2-12	90170-20255	10-17
	30-29	90175-06012	4-17
	10-16	90175-06013	26-17
	11-28	90179-08148	25-28
	23-20	90179-08299	1- 5
	26-12	90179-12244	9-18
	25-29	90179-20255	11-29
	18-28	90179-22330	19-18
	13- 5	90179-25033	19-17
	26-16	90185-08054	14-13
			24-25
		90185-10037	19- 9
		90201-06042	13- 7
		90201-06067	15- 2
			15- 9
			15-13
			19-21
		90201-06407	21- 8
		90201-06571	16- 5

NUMERICAL INDEX

PART NO.	REF. NO.	PART NO.	REF. NO.
90201-06571	16-19	90387-082E1	24-44
90201-08083	25-30	90387-08258	6-13
	28- 4	90387-08699	24-49
	28-12	90387-121E8	19- 7
	10-22	90387-15535	23-31
	24-26	90387-16776	7- 8
	14-19		7-12
	14-22	90387-201E3	24-29
	19- 6	90387-201E4	24-28
	19- 5	90387-25663	11-26
	3-18	90430-05009	25-21
	14-18	90430-06016	8-14
	26- 9		30-41
	9-15	90430-12038	7-20
	10-27		30-42
	9- 8	90445-08577	10-30
	11-10	90445-09300	21-24
	11-21	90445-11182	21-20
	9- 4	90460-51109	4- 8
	11- 4	90460-68120	4-10
	11-14	90462-05005	27- 4
	21-18	90462-14055	25-33
	19- 8	90467-10008	21-21
	15- 5	90467-20030	4-13
	11- 7	90468-26048	9- 3
	11-17	90480-12053	16- 6
	2-12	90480-13197	4-18
	30-29	90480-22263	18-32
	10-16	90501-10245	26-15
	11-28	90501-12081	9-14
	23-20	90501-24408	10-12
	26-12	90506-16036	23- 9
	25-29	90506-20192	26-10
	18-28	90506-20223	6-10
	13- 5	90507-20002	24-10
	26-16	90507-20030	6- 3
		90507-29008	26- 2
		90508-14423	10-28
		90508-20023	26-24
		90508-20415	13- 4
		90508-20425	23-23
		90508-26421	12- 8
		90508-30422	9- 5
		90508-32374	13-12
		90560-12171	13-11
		90560-15116	23- 2
		91316-06020	4- 9
		91316-06025	8-10
		91316-06045	7- 5
			7- 5
		91316-06050	7- 4
		91316-06060	7- 3
		91316-06075	7- 2
		91401-20012	23-22
			25-32
			26-14
		91401-20015	24-48
		91401-20025	18-27
			26- 5
		91401-30022	18-30
		91402-16015	5-38
		91402-20018	19-10
		91810-05016	7-11
		91810-17016	1-11
		92501-06010	7-16
		92501-06012	7-14
			7-18
			16-14
		92501-06015	16- 3
			16-17
		92501-06020	3-15
			17-20
		92501-06025	25-34
			27- 2
		92502-06016	18-35
		92506-06008	8-13
		92506-06025	8- 5
		92506-06035	8- 3
		92701-06012	7- 7
		92901-03100	4- 5
		92901-04100	3-11
			3-13
		92901-05100	17-30
		92901-05200	17-31
		92901-06100	4-20
			6-19
			16- 4
			16-15
			16-18
			17-21
			21- 5
			25-35
			27- 3
		92901-06200	16-16
			23-21
			26-13

NUMERICAL INDEX

PART NO.	REF. NO.	PART NO.	REF. NO.	PART NO.	REF. NO.
92901-06600	3-16 6-20 17-22 21- 6 25-37	93103-40091	2-17 30-46 24- 8 17- 7 26- 8	93507-32009	9-13
92901-08100	6- 7 10-21 14- 6 17-18 17-26 20-35	93104-11056 93108-35004 93109-14021 93109-20014	30-46 24- 8 17- 7 26- 8 9-10 30-50 17- 8 8-12 30-40	93515-32029	10-19
92901-08200	6- 5 14-12	93210-14104 93210-29282	30-40 10- 5 30-43 24-31	93604-26132	18-15
92901-08600	6- 8 14- 7 17-19 17-27	93306-00406 93306-00418 93306-00422 93306-20107	24- 5 24- 4 12- 4 12-16	93606-14154	12-13
92901-10200	14- 9	93306-20203	23- 4	93608-25150	13-10
92901-12100	3-19	93306-20205	23- 5	94130-21659	23-26
92901-12600	18-29	93306-20540	11- 2	94151-18662	24-19
92901-16100	17-13	93306-20544	11-24	94227-21123	23-27
92901-18100	10- 3 24-38	93306-30615	2-13 2-16	94251-18150	24-20
92902-03600	5-16	93310-418E9	2- 5	94330-21084	23-28
92902-04200	16-13		30-31	94340-18086	24-21
92902-05100	5-13	93310-42541	2-11	94416-21234	23-24
92902-06100	15- 4 15- 8 15-12	93311-62035	30-30 11-11 11-23	94425-18280	24-17
92902-06200	22- 9	93315-21721	10-25	94585-20108	24-40
92902-06600	18-37	93317-22214	17- 3	94585-20112	24-40
92902-08200	16- 2	93332-00001	19-14	94685-20001	24-41
92902-10600	18-26	93332-00008	19-15	95301-06600	23-106
92906-05100	28- 8 28-16	93342-22208 93399-99905	17- 2 24-43	95301-06700	23-17
92906-06100	8- 6	93410-17008	9- 9	95302-10700	18-25
92906-06600	8- 7	93410-20038	11-22	95302-10900	26- 4
93101-12004	13- 9	93430-10015	26- 7	95311-08700	10-23
93102-17004	30-49	93430-10016	9-16	95601-06100	22- 8 28- 6 28-14
93102-20009	10-26	93440-25019	11-15	95601-08100	26-23
93102-28022	30-47	93440-25084	11- 5	95601-10100	14-10
93102-32136	23- 6	93440-50078	18-23	95611-08100	24-47
93103-30092	24- 6 11-25 30-48	93450-19052	2- 4 30- 5	95701-12100	1-10
	2-14 30-45		30-20 30-25	95702-06300	17-24
				95702-08300	14-21
				95811-08075	14- 3
				95811-08165	14-11
				95811-10055	14- 8
				95821-08035	19-13
				95821-08040	19-11
				97301-06012	21- 4
				97301-06015	15- 7 15-11
				97301-06016	4-19 6-18
				97301-06020	26-26
				97301-06050	17-23
				97301-08016	6- 6 17-17
				97301-08035	17-25
				97301-08055	14-20
				97302-06020	15- 3

NUMERICAL INDEX

PART NO.	REF. NO.	PART NO.	REF. NO.
97302-06035	22- 7	97302-06035	22- 7
97321-06020	13- 8	97321-06020	13- 8
97321-08025	14- 5	97321-08025	14- 5
97602-03108	5-15	97602-03108	5-15
97702-40512	16-12	97702-40512	16-12
97801-06012	19-20	97801-06012	19-20
98501-03008	4- 4	98501-03008	4- 4
98501-04005	18- 4	98501-04005	18- 4
98501-04014	3-12	98501-04014	3-12
98501-04035	3-10	98501-04035	3-10
98501-05010	17-29	98501-05010	17-29
98501-05015	5-12	98501-05015	5-12
98501-05016	25- 8	98501-05016	25- 8
98506-05020	25-19 28- 7 28-15	98506-05020	25-19 28- 7 28-15
98701-05016	12- 6	98701-05016	12- 6
98902-06018	21-10	98902-06018	21-10
98906-05010	25-18	98906-05010	25-18
*	1- 3	*	1- 3

PARTS NAME INDEX

DESCRIPTION	REF. NO.
AIR CLEANER CASE COMP.	4-11
AIR VALVE COMP.	20-27
ARM, tensioner	17-14
AXLE, drive	11-12
AXLE, main (14T)	11- 1
AXLE, wheel	23-30
*	24-37
BALL	9-13
*	10-19
BAND	20-22
*	20-24
BAND, battery	3-21
BAND, rim (3.00-21)	23-28
BAND, rim (4.00-18)	24-21
BAND, switch cord	3-23
*	25-39
*	27- 6
*	28-18
BAND, tank fitting 1	21-11
BAR, shift fork guide 1	12-14
BAR, shift fork guide 2	12-15
BAR, tension	24-42
BASE, magneto	3- 3
BEARING	11- 2
*	11-24
*	12- 4
*	17- 2
*	19-14
*	19-15
*	24- 4
*	24-43
BEARING (B6004Z)	24- 5
BEARING (B6201)	12-16
BEARING (B6202)	23- 5
BEARING (B6202RS)	23- 4
BEARING (B6306)	2-13
*	2-16
BEARING, cylindrical	2- 5
*	2-11
*	10-25
*	11-11
*	11-23
*	17- 3
*	30-30
*	30-31
BODY, cap	21-22
BODY, float chamber 1	5- 2

PARTS NAME INDEX

DESCRIPTION	REF. NO.
BOLT	4- 9
*	4-19
*	6- 6
*	6-15
*	6-17
*	6-18
*	7- 2
*	7- 3
*	7- 4
*	7- 5
*	8-10
*	13- 8
*	14- 5
*	14-20
*	15- 3
*	15- 7
*	15-11
*	17-17
*	17-23
*	17-25
*	18-24
*	21- 4
*	22- 5
*	22- 7
*	23-14
*	24-14
*	24-35
*	25-38
*	26-22
*	26-26
*	28- 5
*	28-13
BOLT 1	20-33
BOLT, axle holder	20-32
BOLT, cap	20-25
BOLT, flange	14- 3
*	14- 8
*	14-11
*	19-11
*	19-13
BOLT, hexagon socket head	20-34
*	24-24
BOLT, stopper	12- 9
BOLT, stud	1- 4
*	1- 8
*	1- 9
BOLT, washer based	26-25
BOLT, with hole	24-45
*	24-46

PARTS NAME INDEX

DESCRIPTION	REF. NO.
BOLT, with hole	26- 3
BOLT, with washer	21- 9
BOOT	20-21
BOSS, clutch	10- 8
BOSS, kick crank	9-12
BRACKET, footrest 1	26-19
BRACKET, footrest 2	26-21
BRACKET, front upper 1	14- 2
BRACKET, rear upper 1	14- 4
BRACKET, seat	22- 3
*	22- 4
BRAKE SHOE COMP.	23- 8
*	24- 9
BUMP, stop	18- 9
BUSH	14-17
*	17- 6
BUSH 1	19- 4
BUSH, rear shock absorber	18- 3
BUSH, shock absorber lower	18-12
BUSH, solid	17- 9
*	18-13
*	24-32
C.D.I. MAGNETO ASSY	3- 1
C.D.I. UNIT ASSY	3-20
CABLE, brake	25-26
CABLE, clutch	25-23
CABLE, throttle 1	25-22
*	25-22
CAMSHAFT	23-10
*	24-11
CAP	24-50
CAP, case	18- 8
CAP, front fork	20-26
CAP, gear	25-17
CAP, grip lower	25- 7
*	25-15
CAP, grip upper	25- 6
*	25-14
CAP, plunger	5-36
CARBURETOR ASSY 1	5- 1
CHAIN, drive (DID520DS 108L)	24-40
CHAIN, drive (DID520DS 112L)	24-40
CIRCLIP	2- 4
*	9- 9
*	9-16
*	11- 5
*	11-15
*	11-22

PARTS NAME INDEX

DESCRIPTION	REF. NO.
CIRCLIP	18-23
*	26- 7
*	30- 5
*	30-10
*	30-15
*	30-20
*	30-25
CLAMP	3- 9
*	25-33
*	27- 4
CLAMP, hose	4- 8
*	4-10
CLIP	4-13
*	5-21
*	5-34
*	9- 3
*	21-21
CLIP, PlunGer	5-37
CLUTCH ASSY	10- 6
COIL, Pulser	3- 6
COIL, source	3- 4
*	3- 5
COLLAR	6-13
*	7- 8
*	7-12
*	11-26
*	19- 7
*	21- 7
*	23-31
*	24-28
*	24-29
*	24-44
*	24-49
CONNECTING ROD ASSY	30-26
CONNECTOR	5-28
COVER	14-23
*	18-16
COVER, ball race 2	19-16
COVER, caP GriP	25- 9
COVER, crankcase 1	8- 1
COVER, crankcase 2	8- 4
COVER, crankcase 3	8- 8
COVER, dust seal	20- 8
COVER, handle lever	25-24
*	25-27
COVER, hub dust	23-32
*	24-27

PARTS NAME INDEX

DESCRIPTION	REF. NO.
COVER, kick lever	9-17
COVER, Plate	24-30
COVER, PlunGer caP	5-40
COVER, semi-double seat	22- 2
COVER, shift Pedal	13- 6
COVER, side (L.H)	16- 1
COVER, side (R.H)	16- 8
COVER, thrust 1	18-31
COVER, thrust 2	17- 5
CRANK 1	2- 7
CRANK 2	2- 8
CRANKCASE 1	7- 1
CRANKCASE 2	7- 9
CRANKSHAFT ASSY	2- 6
CROWN, handle	19- 1
CYLINDER COMP., front fork	20-11
CYLINDER 1	1- 6
DAMPER	3-22
*	16- 9
DAMPER, locatinG 1	16- 7
*	21-25
DAMPER, locatinG 2	21- 2
DAMPER, locatinG 3	21-26
DAMPER, muffler	6-12
DAMPER, seat	22- 6
DAMPER, sub tank	18-33
DUMPER SUB ASSY	18- 2
ELEMENT, air cleaner	4-14
EMBLEM	16-20
EMBLEM 2	19-22
END, rod 1	23-18
END, rod 2	23-19
EXHAUST PIPE ASSY 1	6- 1
FENDER, front	15- 1
FENDER, rear	15- 6
FLANGE, sPacer	24- 3
FLANGE, sPacer 2	23- 3
FLAP	15-14
FLOAT	5- 7
FOOTREST 1	26-18
FOOTREST 2	26-20
FORK, shift 1	12-10
FORK, shift 2	12-11
FORK, shift 3	12-12
FRAME COMP	14- 1
FRONT FORK ASSY	20- 1
FUEL COCK ASSY 1	21-12

PARTS NAME INDEX

DESCRIPTION	REF. NO.
FUEL TANK COMP.	21- 1
GASKET	7-20
*	8-14
*	20-18
*	21-13
*	25-21
*	30-41
*	30-42
GASKET KIT	30-32
GASKET, caP	21-23
GASKET, crankcase cover	8- 2
*	30-38
GASKET, crankcase cover 3	8- 9
*	30-39
GASKET, cylinder	1- 7
*	30-34
GASKET, cylinder head 1	1- 2
*	30-33
GASKET, drain Plug	20-19
GASKET, exhaust Pipe	6- 2
*	30-37
GASKET, float chamber	5- 3
*	30-36
GASKET, valve seat	4- 6
*	30-35
GAUGE, air	14-27
GEAR, bevel	25-16
GEAR, kick (26T)	9- 2
GEAR, Primary drive (24T)	10- 1
GEAR, sProcket idla (21T)	9- 7
GEAR, 1st wheel (30T)	11-20
GEAR, 2nd Pinion (16T)	11- 9
GEAR, 2nd wheel (28T)	11-13
GEAR, 3rd Pinion (19T)	11- 6
GEAR, 3rd wheel (25T)	11-18
GEAR, 4th Pinion (22T)	11- 3
GEAR, 4th wheel (23T)	11-19
GEAR, 5th Pinion (24T)	11- 8
GEAR, 5th wheel (20T)	11-16
GRAPHIC SET	21-27
GRIP (L.H)	25- 2
GRIP (R.H)	25- 3
*	25-10
GROMMET	4-18
*	16- 6
*	18-32
*	25-13
GUARD, chain	17-15
GUARD, mud	15-10

PARTS NAME INDEX

DESCRIPTION	REF. NO.
GUIDE	4-15
GUIDE, cable	5-20
*	20-31
GUIDE, sPring	9- 6
GUIDE, sPring 1	18-20
GUIDE, sPring 2	18-21
HANDLEBAR	25- 1
HEAD, cylinder 1	1- 1
HOLDER	5-39
*	7-15
*	25-25
HOLDER, cable	19- 2
HOLDER, damPer	21- 3
HOLDER, guide	4-16
HOLDER, handle lower	19- 3
HOLDER, handle uPPer	19-12
HOLDER, lever lower 1	28- 2
*	28-10
HOLDER, lever 1	28- 1
HOLDER, lever 2	28- 9
HOLDER, sub tank	18-34
HOOK, sPring	6- 9
HOSE	10-30
*	21-20
*	21-24
HOUSING, seal ring	18- 7
HUB, front	23- 1
HUB, rear	24- 1
IGNITION COIL ASSY	27- 1
INNER TUBE COMP.1	20-10
JET, main (#380)	5- 6
JET, main (#390)	5- 6
JET, main (#400)	5- 6
JET, Pilot (#45.0)	5- 4
JOINT, cable	25-31
JOINT, carburetor	4- 7
JOINT, chain	24-41
KEY, straight	10- 2
*	12- 5
KEY, woodruff	2-15
KICK AXLE ASSY	9- 1
KICK CRANK ASSY	9-11
LEAD WIRE ASSY	3- 8
LEVER 1	28- 3
LEVER 2	28-11
LEVER, camshaft	24-13
LEVER, camshaft 1	23-11
LEVER, camshaft 2	23-12
LEVER, cock	21-16

PARTS NAME INDEX

DESCRIPTION	REF. NO.
METAL, slide 1	20- 6
NEEDLE	5-33
NEEDLE VALVE ASSY	5- 8
NOZZLE, main	5- 5
NUT	1- 5
*	3-17
*	9-18
*	10- 4
*	10-17
*	10-23
*	11-29
*	17-12
*	18-18
*	18-25
*	19-17
*	19-18
*	23-15
*	23-17
*	24-16
*	24-36
*	24-39
*	25-28
*	25-36
*	26-27
NUT, adjusting	18-14
NUT, cable adjusting	5-19
*	5-26
NUT, flange	1-10
NUT, nylon	14-21
*	17-24
NUT, self-locking	14-13
*	19- 9
*	24-25
NUT, slotted	26- 4
NUT, u	14-10
*	22- 8
*	24-47
*	26-23
*	28- 6
*	28-14
NUT, wing	4-17
*	26-17
O-RING	5-18
*	5-32
*	8-12
*	10- 5
*	20-13
*	20-29

PARTS NAME INDEX

DESCRIPTION	REF. NO.
O-RING	20-30
*	21-15
*	24-31
*	30-40
*	30-43
OIL SEAL	2-14
*	2-17
*	9-10
*	10-26
*	11-25
*	13- 9
*	17- 7
*	17- 8
*	20- 5
*	23- 6
*	24- 6
*	24- 8
*	26- 8
*	30-45
*	30-46
*	30-47
*	30-48
*	30-49
*	30-50
OIL SEAL KIT	30-44
PACKING	25-20
PANEL 1	16-11
PEDAL, brake	26- 6
PEDAL, shift	13- 2
*	13- 3
PIN	13- 5
*	26-16
PIN, clevis	18-28
*	23-20
*	25-29
*	26-12
PIN, cotter	5-38
*	18-27
*	18-30
*	19-10
*	23-22
*	24-48
*	25-32
*	26- 5
*	26-14
PIN, crank 1	2- 9
*	30-28
PIN, dowel	1-11

PARTS NAME INDEX

DESCRIPTION	REF. NO.
PIN, dowel	7-11
*	12-13
*	13-10
*	18-15
PIN, float	5-9
PIN, piston	2-3
*	30-4
*	30-9
*	30-14
*	30-19
*	30-24
PIPE	5-11
*	5-14
PISTON (STD)	2-1
*	2-1
*	30-2
*	30-2
PISTON (1ST O/S 0.25MM)	2-1
*	30-7
PISTON (2ND O/S 0.50MM)	2-1
*	30-12
PISTON (3RD O/S 0.75MM)	2-1
*	30-17
PISTON (4TH O/S 1.00MM)	2-1
*	30-22
PISTON ASSY (STD)	30-1
PISTON ASSY (1ST O/S)	30-6
PISTON ASSY (2ND O/S)	30-11
PISTON ASSY (3RD O/S)	30-16
PISTON ASSY (4TH O/S)	30-21
PISTON RING SET (STD)	2-2
*	30-3
PISTON RING SET (1ST O/S)	2-2
*	30-8
PISTON RING SET (2ND O/S)	2-2
*	30-13
PISTON RING SET (3RD O/S)	2-2
*	30-18
PISTON RING SET (4TH O/S)	2-2
*	30-23
PLATE	5-29
*	7-17
PLATE, bearing cover	7-6
*	7-13
PLATE, brake shoe	23-7
*	24-7
PLATE, cleaner case fitting	4-21
PLATE, clutch 2	10-10

PARTS NAME INDEX

DESCRIPTION	REF. NO.
PLATE, friction	10-11
PLATE, number	19-19
PLATE, Pressure 1	10-9
PLATE, side 1	12-3
PLATE, thrust 1	10-15
PLUG	7-10
*	14-14
PLUG CAP ASSY	27-5
*	27-5
PLUG, drain	20-20
PLUG, oil level	8-11
PLUG, screw	5-31
PLUG, sPark (CHAMPION N-3)	1-3
PLUG, straight screw	7-19
PLUNGER, starter	5-42
PRIMARY DRIVEN GEAR COMP.(63T)	10-7
PROTECTOR, chain	17-28
PULLER, chain 1	24-34
PULLER, chain 2	24-33
PULLER, rotor	14-25
PUSH LEVER ASSY	10-29
REAR ARM COMP.	17-1
REED VALVE ASSY	4-1
REED, valve	4-2
RIM (1.60-21)	23-24
RIM (2.50-18)	24-17
RING, leaf	25-5
*	25-12
RING, snap	20-4
ROD, brake	26-11
ROD, connecting	2-10
*	23-16
*	30-27
ROD, Push	18-5
ROD, Push 1	10-18
ROD, Push 2	10-24
ROTOR ASSY	3-2
SCREW	10-20
*	21-19
SCREW, air adjusting	5-23
SCREW, bind	21-10
*	25-18
SCREW, boot band	20-23
SCREW, flat head	7-7
*	12-6
SCREW, lever fitting	21-17
SCREW, Pan head	3-10

PARTS NAME INDEX

DESCRIPTION	REF. NO.
SCREW, Pan head	3-12
*	3-14
*	3-15
*	4-4
*	5-12
*	7-14
*	7-16
*	7-18
*	8-3
*	8-5
*	8-13
*	16-3
*	16-14
*	16-17
*	17-20
*	17-29
*	18-4
*	18-35
*	19-20
*	25-8
*	25-19
*	25-34
*	27-2
*	28-7
*	28-15
SCREW, Pan head with washer	5-15
SCREW, tapping	16-12
SCREW, throttle	5-25
SCREW, with washer	10-13
SEAL	4-12
SEAL 1	16-10
SEAL, camshaft	23-13
*	24-12
SEAL, dust	18-6
*	20-7
SEAL, Guard	17-10
SEAL, mud Guard	15-15
SEAT, spring	5-35
SEAT, spring lower	18-22
SEAT, spring upper	18-17
*	20-17
SEGMENT	12-2
SEMI-DOUBLE SEAT ASSY	22-1
SHAFT	14-15
SHAFT, Pivot	17-11
SHIFT CAM ASSY	12-1
SHIFT SHAFT ASSY	13-1
SHIM (0.3T)	17-4

PARTS NAME INDEX

DESCRIPTION	REF. NO.
SHIM, camshaft	24-15
SHOCK ABSORBER ASSY, rear	18- 1
SILENCER, exhaust	6-11
SPACER	3- 7
*	13-11
*	20-28
*	23- 2
SPACER 1	10-14
SPACER, bead	23-29
*	24-22
SPACER, bearing	24- 2
SPANNER, special	14-26
SPINDLE, taper	20-14
SPOKE SET, front	23-25
SPOKE SET, rear	24-18
SPRING	18-19
*	21-14
*	29- 1
*	29- 1
SPRING, air adjusting	5-22
SPRING, compression	9-14
*	10-12
*	26-15
SPRING, front fork	20-16
SPRING, front fork (K=0.275)	29- 2
SPRING, front fork (K=0.31)	29- 2
SPRING, Plunger	5-41
SPRING, sub	20-12
SPRING, tension	6- 3
*	6-10
*	23- 9
*	24-10
*	26- 2
*	26-10
SPRING, throttle valve	5-17
SPRING, torsion	9- 5
*	10-28
*	12- 8
*	13- 4
*	13-12
*	23-23
*	26-24
SPROCKET, drive (13T)	11-27
SPROCKET, drive (14T)	11-27
SPROCKET, drive (15T)	11-27
SPROCKET, driven (44T)	24-23
SPROCKET, driven (46T)	24-23
SPROCKET, driven (48T)	24-23
SPROCKET, driven (50T)	24-23
SPROCKET, driven (52T)	24-23

PARTS NAME INDEX

DESCRIPTION	REF. NO.
STAND, side	26- 1
STAY 2	4-22
STAY, muffler 1	6-16
STAY, muffler 2	6- 4
STOPPER LEVER ASSY	12- 7
STOPPER, reed valve	4- 3
SUPPORT, bump stop	18-10
SUPPORT, chain	17-16
SWITCH, handle 1	28-17
TENSIONER	14-16
TIRE (3.00-21)	23-26
TIRE (5.10-18)	24-19
TOOL KIT	14-24
TOP, mixing chamber	5-24
TUBE (2.75-21)	23-27
TUBE (5.10-18)	24-20
TUBE, outer 1	20- 2
TUBE, outer 2	20- 3
TUBE, throttle guide	25- 4
*	25-11
UNDER BRACKET COMP.	20-15
UPPER BRACKET SUB ASSY	18-11
VALVE, throttle 1	5-27
WASHER	2-12
*	5-16
*	11- 7
*	11-17
*	15- 5
*	16- 2
*	18-37
*	22- 9
*	30-29
WASHER, lock	10-16
*	11-28
WASHER, main jet	5-30
WASHER, needle valve	5-10
WASHER, oil seal	20- 9
WASHER, plain	6- 5
*	14- 9
*	14-12
*	16-13
*	16-16
*	17-31
*	23-21
*	26-13
WASHER, Plate	3-16
*	3-18
*	6- 8
*	6-20

PARTS NAME INDEX

DESCRIPTION	REF. NO.
WASHER, Plate	8- 7
*	9- 4
*	9- 8
*	9-15
*	10-22
*	10-27
*	11- 4
*	11-10
*	11-14
*	11-21
*	13- 7
*	14- 7
*	14-18
*	14-19
*	14-22
*	15- 2
*	15- 9
*	15-13
*	16- 5
*	16-19
*	17-19
*	17-22
*	17-27
*	18-26
*	18-29
*	19- 5
*	19- 6
*	19- 8
*	19-21
*	21- 6
*	21- 8
*	21-18
*	24-26
*	25-30
*	25-37
*	26- 9
*	28- 4
*	28-12
WASHER, special	6-14
WASHER, spring	3-11
*	3-13
*	3-19
*	4- 5
*	4-20
*	5-13
*	6- 7
*	6-19
*	8- 6
*	10- 3

PARTS NAME INDEX

DESCRIPTION	REF. NO.
WASHER, sPring	10-21
*	14- 6
*	15- 4
*	15- 8
*	15-12
*	16- 4
*	16-15
*	16-18
*	17-13
*	17-18
*	17-21
*	17-26
*	17-30
*	18-36
*	20-35
*	21- 5
*	24-38
*	25-35
*	27- 3
*	28- 8
*	28-16